

1200 Dual Fuel

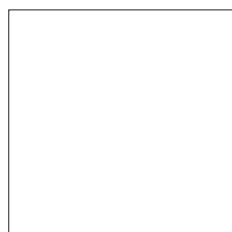

User Guide

&

Installation & Service Instructions

MERCURY

U110067 - 01

Contents

1. Before You Start...	1	6. Troubleshooting	16
Important!	1	7. Installation	18
Installation and Maintenance	1	Dear Installer	18
Peculiar smells	1	Safety Requirements and Regulations	18
If you smell gas	1	Provision of Ventilation	18
Ventilation	1	Location of Cooker	19
Personal Safety	1	Conversion	19
Cooker Care	2	Positioning the Cooker	20
Cleaning	2	Moving the Cooker	20
2. Cooker Overview	3	Completing the Move	21
Hotplate Burners	3	Fitting the Flue	22
Wok Burner	4	Installing the Flue Vent	22
The Wok Ring	4	Fitting a Stability Bracket	22
The Griddle (optional extra)	5	Repositioning the Cooker following Connection	22
The Glide-out Grill	5	Conversion to Another Gas	23
The Ovens	6	Levelling	23
Accessories	8	Gas Connection	23
Storage	9	Electrical Connection	24
3. Cooking Tips	10	Final Fitting	25
Cooking with a Multi-function Oven	10	Customer Care	25
General Oven Tips	10	8. Conversion to LP gas	26
4. Cooking Table	11	Injectors	26
5. Cleaning Your Cooker	12	Reassembling to Liquid Propane Gas	27
Essential Information	12	Stick on Label	27
Daily Care	12	Pressure Testing	27
Cleaning for Spills	12	9. Circuit Diagram	28
Cooktop Burners	12	10. Technical Data	29
Stainless Steel Main Top	13		
Griddle (optional extra)	13		
Glide-out grill	13		
Control Panel and Oven Doors	14		
Ovens	14		
Cleaning Table	15		

1. Before You Start...

Your cooker should give you many years of trouble-free cooking if installed and operated correctly. It is important that you read this section before you start, particularly if you have not used a dual fuel cooker before.

Important!

⚠ This appliance is designed for domestic cooking only. Using it for any other purpose could invalidate any warranty or liability claim. In particular, the oven should NOT be used for heating the kitchen – besides invalidating claims this wastes fuel and may overheat the control knobs.

⚠ This appliance is for use in Great Britain and the Republic of Ireland. It is a Cat II2H3+ cooker and is set for G20 at 20mbar. (A conversion kit for LPG is supplied with the cooker).

⚠ This cooker is a Class 1 appliance.

Installation and Maintenance

In the UK, the cooker must be installed by a Gas Safe registered engineer. The electrical installation should be in accordance with BS 7671. Otherwise, all installations must be in accordance with the relevant instructions in this booklet, with the relevant national and local regulations, and with the local gas and electricity supply companies' requirements.

Ensure that the gas supply is turned on and that the cooker is wired in and switched on (the cooker needs electricity).

Only a qualified service engineer should service the cooker, and only approved spare parts should be used.

Always allow the cooker to cool and then switch it off at the mains before cleaning or carrying out any maintenance work, unless specified otherwise in this guide.

Peculiar smells

When you first use your cooker it may give off a slight odour. This should stop after a little use.

Before using for the first time, make sure that all packing materials have been removed and then, to dispel manufacturing odours, turn the ovens to 200°C and run for an hour.

Before using the grill for the first time you should also turn on the grill and run for 15 minutes with the grill pan in position, pushed fully back, and the grill door open.

Make sure the room is well ventilated to the outside air (see 'Ventilation' below). People with respiratory or allergy problems should vacate the area for this brief period.

If you smell gas

- DO NOT turn electric switches on or off.
- DO NOT smoke
- DO NOT use naked flames
- DO turn off the gas at the meter or cylinder
- DO open doors and windows to get rid of the gas
- DO keep people away from the area affected
- Call your gas supplier.

If you are using natural gas in the UK, ring the National Grid on: 0800 111 999.

Ventilation

The use of a gas cooking appliance results in the production of heat and moisture in the room in which it is installed. Therefore, ensure that the kitchen is well ventilated: keep natural ventilation holes open or install a powered cooker hood that vents outside. If you have several burners on, or use the cooker for a long time, open a window or turn on an extractor fan.

Personal Safety

⚠ DO NOT modify this appliance.

⚠ This appliance is not intended for use by persons (including children) with reduced physical, sensory or mental capabilities, or lack of experience and knowledge, unless they have been given supervision or instruction concerning use of the appliance by a person responsible for their safety.

⚠ This appliance is not intended for use by young children or infirm persons unless they have been adequately supervised by a responsible person to ensure that they can use the appliance safely.

⚠ DO NOT use a steam cleaner on your cooker.

⚠ Accessible parts will become hot during use and will retain heat even after you have stopped cooking. Keep babies and children away from the cooker and never wear loose-fitting or hanging clothes when using the appliance.

Always be certain that the controls are in the OFF position when the oven is not in use, and before attempting to clean the cooker.

⚠ When the oven is on, DO NOT leave the oven door open for longer than necessary, otherwise the control knobs may become very hot.

⚠ When using the grill, make sure that the grill pan is in position and pushed fully in, otherwise the control knobs may become very hot.

Always keep combustible materials, e.g. curtains, and flammable liquids a safe distance away from your cooker.

⚠ DO NOT spray aerosols in the vicinity of the cooker while it is on.

Use dry oven gloves when applicable – using damp gloves might result in steam burns when you touch a hot surface. Do not use a towel or other bulky cloth in place of a glove – it might catch fire if brought into contact with a hot surface.

⚠ NEVER operate the cooker with wet hands.

⚠ DO NOT use aluminium foil to cover shelves, linings or the oven roof.

⚠ NEVER heat unopened food containers. Pressure build up may make the containers burst and cause injury.

⚠ DO NOT use unstable saucepans. Always ensure that you position the handles away from the edge of the hotplate.

⚠ DO NOT use cooking vessels on the hotplate that overlap the edges.

Never leave the hotplate unattended at high heat settings. Pans boiling over can cause smoking, and greasy spills may catch on fire. Use a deep fat thermometer whenever possible to prevent fat overheating beyond the smoking point.

⚠ NEVER leave a chip pan unattended. Always heat fat slowly, and watch as it heats. Deep fry pans should be only one third full of fat. Filling the pan too full of fat can cause spill over when food is added. If you use a combination of oils or fats in frying, stir them together before heating, or as the fats melt.

Foods for frying should be as dry as possible. Frost on frozen foods or moisture on fresh foods can cause hot fat to bubble up and over the sides of the pan. Carefully watch for spills or overheating of foods when frying at high or medium high temperatures. Never try to move a pan of hot fat, especially a deep fat fryer. Wait until the fat is cool.

Do not use the top of the flue (the slot along the back of the cooker) for warming plates, dishes, drying tea towels or softening butter.

⚠ DO NOT use water on grease fires and never pick up a flaming pan. Turn the controls off and then smother a flaming pan on a surface unit by covering the pan completely with a well fitting lid or baking tray. If available, use a multipurpose dry chemical or foam-type fire extinguisher.

Cooking high moisture content foods can create a 'steam burst' when the oven door is opened. When opening the oven stand well back and allow any steam to disperse.

Take care that no water seeps into the appliance.

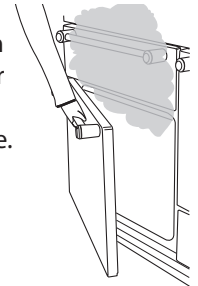

⚠ This appliance is heavy so take care when moving it.

Cooker Care

As steam can condense to water droplets on the cool outer trim of the oven, it may be necessary during cooking to wipe away any moisture with a soft cloth. This will also help to prevent soiling and discolouration of the oven exterior by cooking vapours.

Cleaning

In the interests of hygiene and safety, the cooker should be kept clean at all times as a build up in fats and other food stuff could result in a fire.

Clean only the parts listed in this guide.

Clean with caution. If a wet sponge or cloth is used to wipe spills on a hot surface, be careful to avoid steam burns. Some cleansers can produce noxious fumes if applied to a hot surface.

2. Cooker Overview

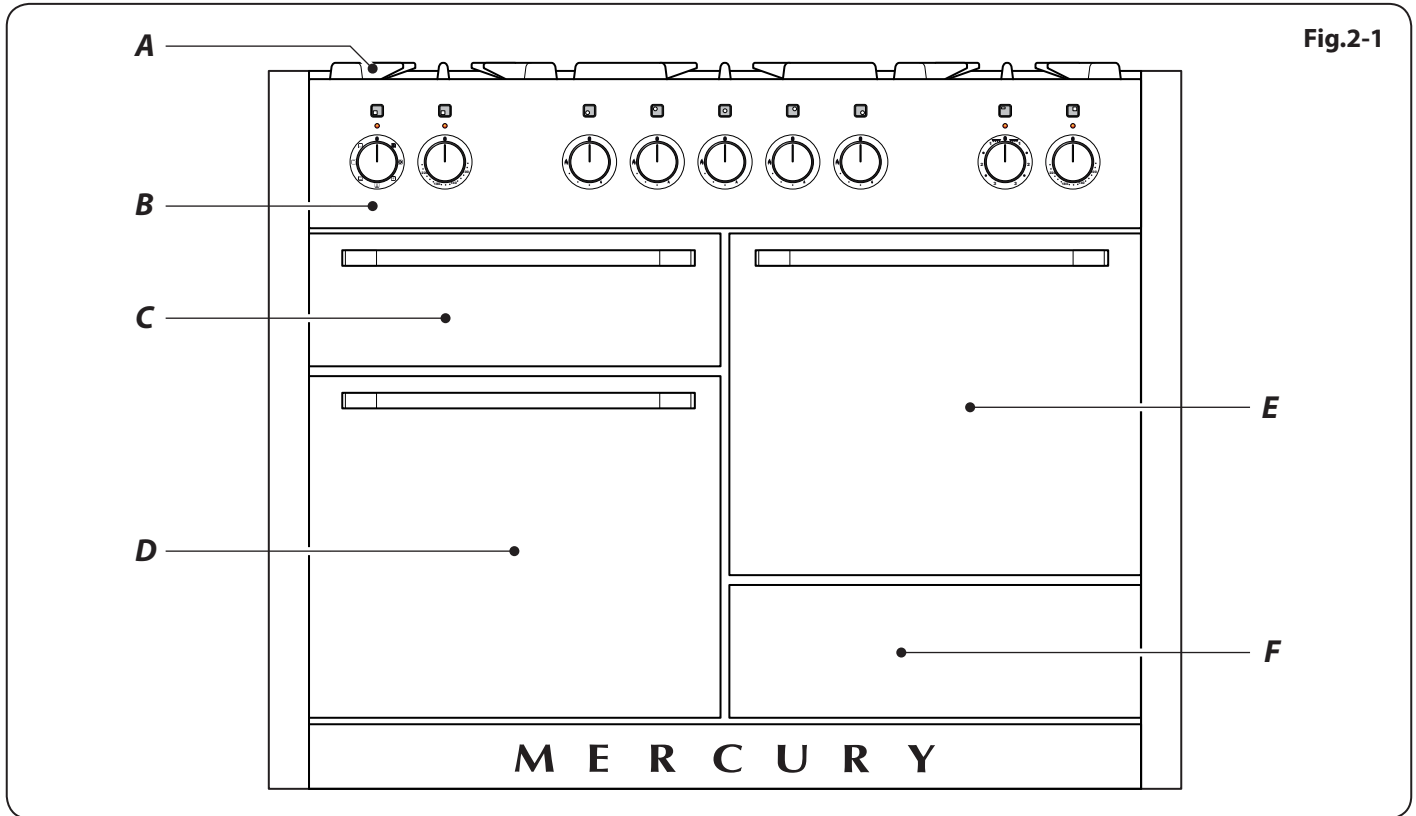

Fig.2-1

The 1200 dual fuel cooker (**Fig.2-1**) has the following features:

- A.** 5 hotplate burners including 1 wok burner
- B.** A control panel
- C.** A glide-out grill
- D.** Main multi-function oven
- E.** Fan oven
- F.** Storage drawer

Hotplate Burners

The drawing by each of the central knobs indicates which burner that knob controls.

Each burner has an FSD that prevents the flow of gas if the flame goes out.

When a hotplate control knob is pressed in, sparks will be made at every burner – this is normal. Do not attempt to disassemble or clean around any burner while another burner is on, otherwise an electric shock could result.

To light a burner, push in the selected burner control knob and turn it to the high position, as indicated by the large flame symbol (🔥) (**Fig.2-2**).

The igniter should spark and light the gas. Keep holding the knob pressed in to let the gas through to the burner for about ten seconds.

If, when you let go of the control knob the burner goes out, then the FSD has not been bypassed. Turn the control knob to the OFF position and wait for one minute before you try again, this time making sure to hold in the control knob for slightly longer.

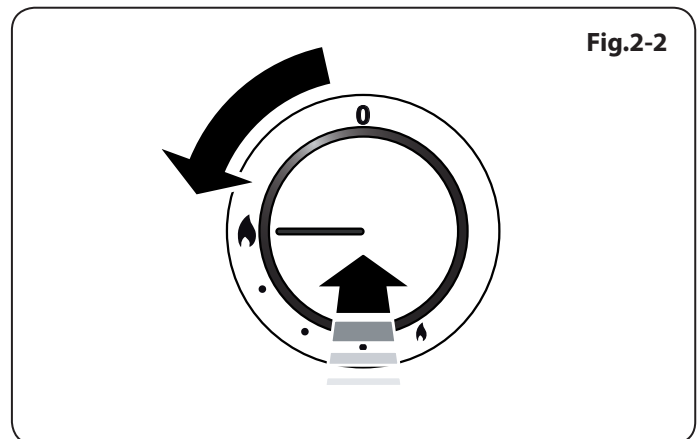
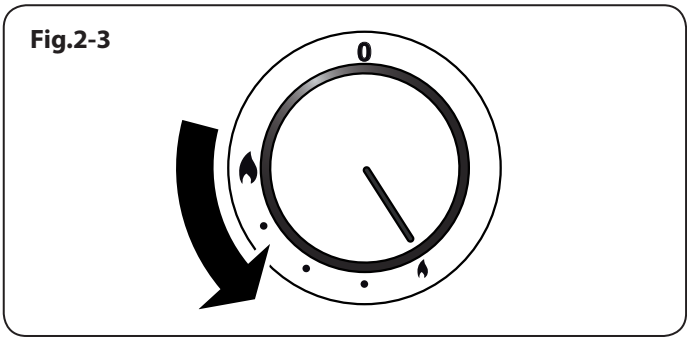

Fig.2-2



Adjust the flame height to suit by turning the knob anti-clockwise (**Fig.2-3**). On this cooker the low position is beyond high, **NOT** between high and off.

If a burner flame goes out, turn off the control knob and leave it for one minute before relighting it.

Ensure that the flames are under the pans. Using a lid will help the contents boil more quickly (**Fig.2-4**).

Large pans should be spaced well apart.

Pans and kettles with concave bases or down turned base rims should not be used (**Fig.2-5**).

Simmering aids, such as asbestos or mesh mats, are **NOT** recommended (**Fig.2-6**). They will reduce burner performance and could damage the pan supports.

You should also avoid using unstable and misshapen pans that may tilt easily, and pans with a very small base diameter, e.g. milk pans, single egg poachers (**Fig.2-7**).

The minimum recommended pan diameter is 120mm. The maximum allowable pan base diameter is 250mm.

DO NOT use cooking vessels on the hotplate that overlap the edges.

Wok Burner

The wok burner is designed to provide even heat over a large area. They are ideal for large pans and stir frying (**Fig.2-8**).

For heating smaller pans, the aforementioned hotplate burners may be more efficient.

You can remove the burner parts for cleaning; see 'Cleaning your cooker'.

You should wipe the enamel top surface of the cooker around the hotplate burners as soon as possible after spills occur. Try to wipe them off while the enamel is still warm.

Note: The use of aluminium pans may cause metallic marking of the pan supports. This does not affect the durability of the enamel and may be cleaned off with an appropriate metal cleaner.

The Wok Ring

The wok ring is designed to fit a Professional 35cm Wok (available from our cookware collection – Part Code RM095). If you use a different wok, make sure that it fits the ring. Woks vary very widely in size and shape. It is important that the wok sits down on the pan support – however, if the wok is too small, the ring will not support it properly (**Fig.2-9**).

The ring should be used on the centre wok burner only. When you fit the ring, check that it is located correctly on the pan support fingers (**Fig.2-10**).

Make sure that the ring is stable and that the wok is sitting level in the ring.

The ring will get very hot in use – allow plenty of time for it to cool before you pick it up.

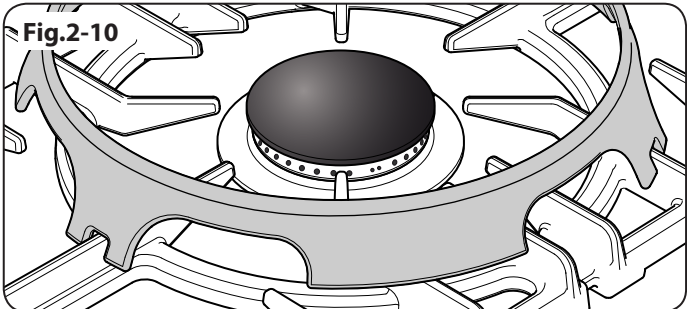
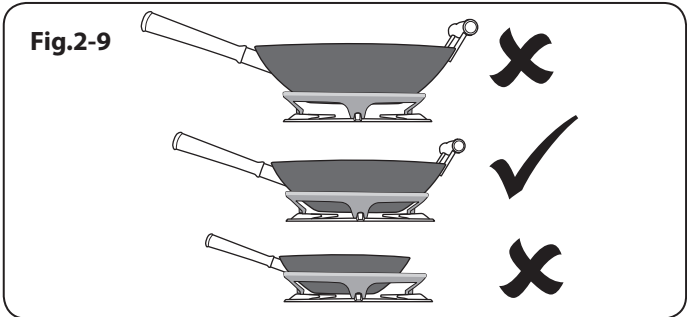
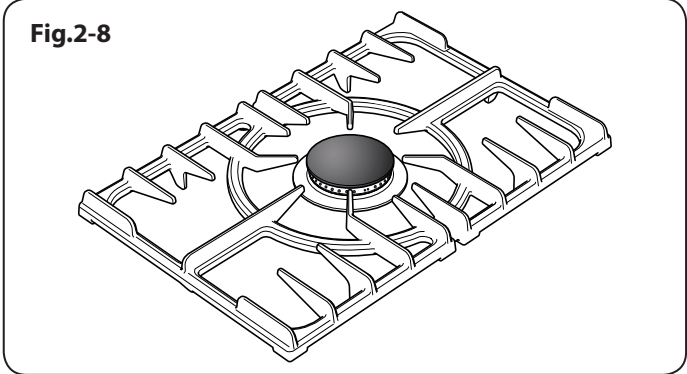
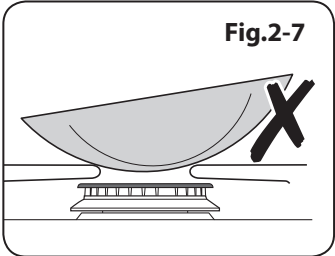
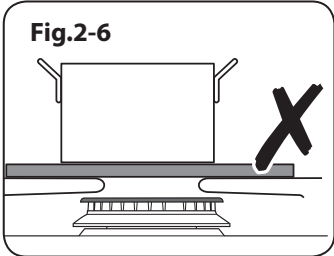
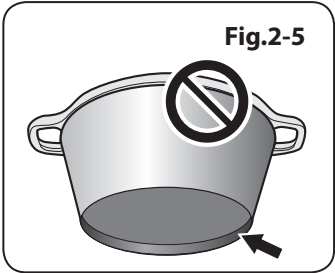
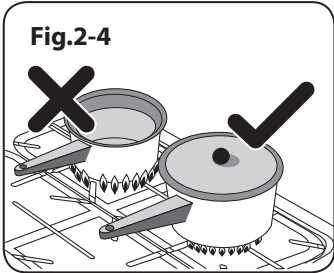

The Griddle (optional extra)

The griddle fits over the left-hand pan supports, front to back (Fig.2-11). It is designed for cooking food on directly. DO NOT use pans of any kind on it. The griddle surface is non-stick and metal cooking utensils (e.g. spatulas) will damage the surface. Use heat resistant plastic or wooden utensils.

⚠ DO NOT put it crossways – it will not fit properly and will be unstable.

⚠ DO NOT put it on any other burners – it is not designed to fit in any of the other pan supports.

Position the griddle over the hotplate burners resting on the pan support (Fig 2-12). Check that it is securely located.

The griddle can be lightly brushed with cooking oil before use. Light the hotplate burners. Adjust the flame heights to suit.

Preheat the griddle for a **maximum of 5 minutes** before adding food. Leaving it longer may cause damage. Turn the control knobs towards the low position, marked with the small flame symbol, to reduce the burner flames.

⚠ Always leave space around the griddle for the gases to escape.

⚠ NEVER fit two griddles side by side.

After cooking, allow the griddle to cool before cleaning.

The Glide-out Grill

Open the door and pull the grill pan carriage forward using the handle (Fig.2-13).

The grill has two elements that allow either the whole area of the pan to be heated or just the right-hand half.

Adjust the heat to suit by turning the knob. To heat the whole grill, turn the knob clockwise (Fig.2-14).

To heat the right-hand half, turn the knob anti-clockwise. The neon indicator light by the grill control will come on.

For best results, slide the carriage back into the grill chamber and preheat the appropriate part(s) of the grill for two minutes. The grill trivet can be removed and the food placed on it while you are waiting for the grill to preheat.

⚠ DO NOT leave the grill on for more than a few moments without the grill pan underneath it, otherwise the knobs may become hot.

Once the grill has preheated, slide the carriage out again. With the trivet back in place with the food on it, slide the carriage back into the grill chamber. Ensure that it is pushed right in.

⚠ Accessible parts may be hot when the grill is in use. Young children should be kept away.

The grill pan grid can be set to four different grilling heights by a combination of turning it back to front and turning it upside down (Fig.2-15).

⚠ Never close the grill door when the grill is on.

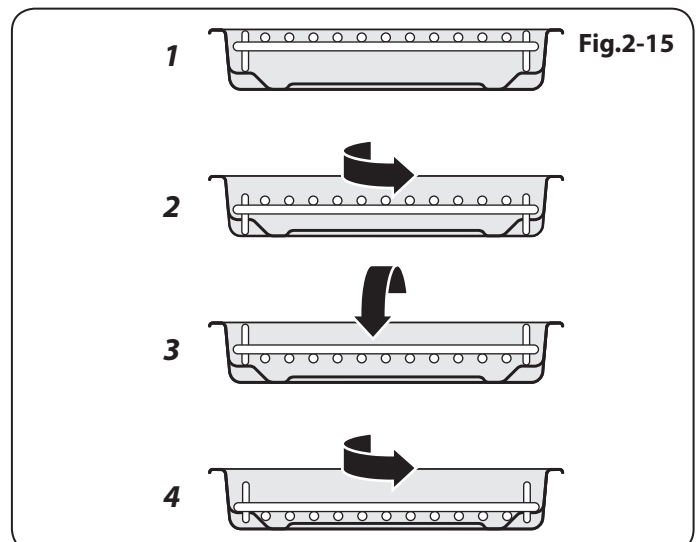
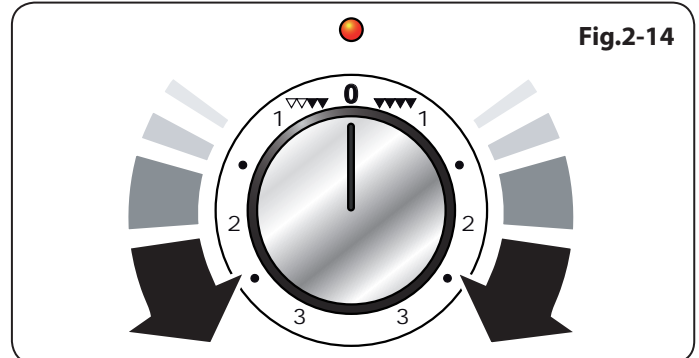
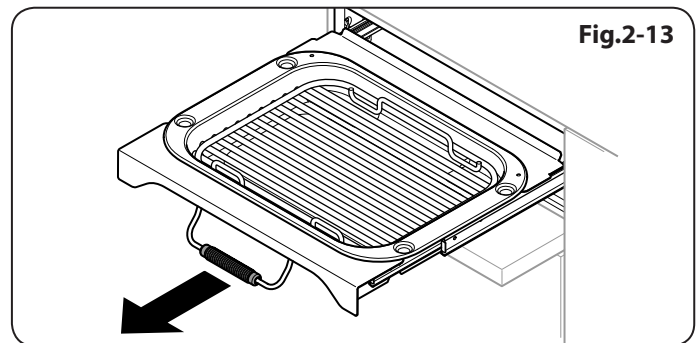
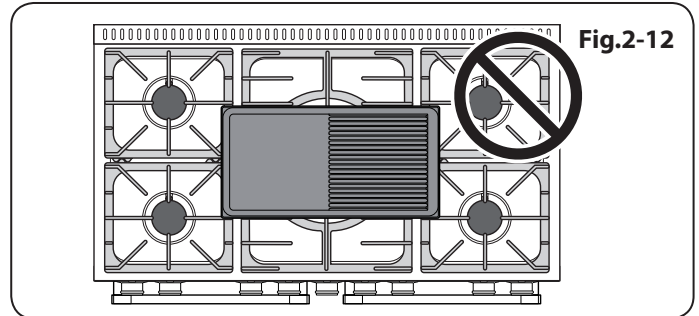
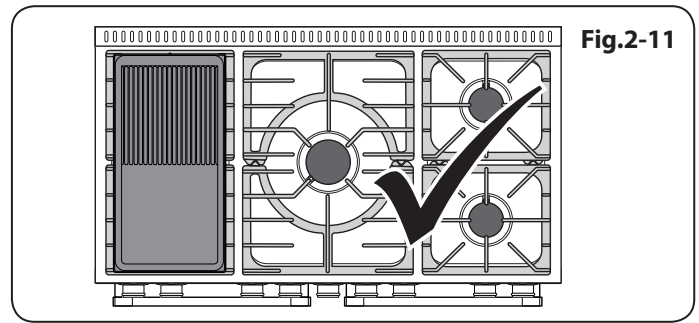

The Ovens

The clock must be set to the time of day before the ovens will work. See the following section on 'The Clock' for instructions on setting the time of day.

References to 'left-hand' and 'right-hand' ovens apply as viewed from the front of the appliance.

The left-hand oven is a programmable multi-function oven, while the right-hand oven is a fanned oven.

The Left-Hand Multi-function Oven

As well as the oven fan and fan element, they are fitted with two extra heating elements, one visible in the top of the oven and the second under the oven base. Take care to avoid touching the top element and element deflector when placing or removing items from the ovens.

The multi-function oven has 3 main cooking functions, **fan**, **fan assisted** and **conventional cooking**. These functions should be used to complete most of your cooking.

The **browning element** and **base heat** can be used in the latter part of the cooking process to fine tune the results to your particular requirements.

Use **fanned grilling** for all your grilling needs and **defrost** to safely thaw small items of frozen food.

Table 2-1 gives a summary of the multi-function modes.

The multi-function ovens have many varied uses. We suggest you keep a careful eye on your cooking until you are familiar with each function. Remember – not all functions will be suitable for all food types.

Please remember that all cookers vary – temperatures in your new ovens may differ to those in your previous cooker.

Multi-function oven functions

Defrost



This function operates the fan to circulate cold air only. No heat is applied. This enables small items such as desserts, cream cakes and pieces of meat, fish and poultry to be defrosted.

Defrosting in this way speeds up the process and protects the food from flies. Pieces of meat, fish and poultry should be placed on a rack, over a tray to catch any drips. Be sure to wash the rack and tray after defrosting.

Defrost with the oven door closed.

Large items, such as whole chickens and joints should not be defrosted in this way. We recommend this be carried out in a refrigerator.

Defrosting should not be carried out in a warm oven or when an adjoining oven is in use or still warm.

Ensure that dairy foods, meat and poultry are completely defrosted before cooking.

Fan oven



This function operates the fan and the heating element around it. An even heat is produced throughout the oven, allowing you to cook large amounts quickly.

Fan oven cooking is particularly suitable for baking on several shelves at one time and is a good 'all-round' function. It may be necessary to reduce the temperature by approximately 10°C for recipes previously cooked in a conventional oven.

If you wish to preheat the oven, wait until the indicator light has gone out before inserting the food.

Fanned grilling



This function operates the fan whilst the top element is on. It produces a more even, less fierce heat than a conventional grill. For best results, place the food to be grilled, on a grid over a roasting tin, which should be smaller than a conventional grill pan. This allows greater air circulation. Thick pieces of meat or fish are ideal for grilling in this way, as the circulated air reduces the fierceness of the heat from the grill.

The oven door should be kept closed while grilling is in progress, so saving energy.

You will also find that the food needs to be watched and turned less than for normal grilling. Preheat this function before cooking.

Fan assisted oven



This function operates the fan, circulating air heated by the elements at the top and the base of the oven. The combination of fan and conventional cooking (top and base heat) makes this function ideal for cooking large items that need thorough cooking, such as a large meat roast.

It is also possible to bake on two shelves at one time, although they will need to be swapped over during the cooking time, as the heat at the top of the oven is greater than at the base, when using this function.

This is a fast intensive form of cooking; keep an eye on the food cooking until you have become accustomed to this function.

Conventional oven (top and base heat)



This function combines the heat from the top and base elements. It is particularly suitable for roasting and baking pastry, cakes and biscuits.

Food cooked on the top shelf will brown and crisp faster than on the lower shelf, because the heat is greater at the top of the oven than at the base, as in 'Fan assisted oven' function. Similar items being cooked will need to be swapped around for even cooking. This means that foods requiring different temperatures can be cooked together, using the cooler zone in the lower half of the oven and hotter area to the top.

Browning element



This function uses the element in the top of the oven only. It is a useful function for the browning or finishing of pasta dishes, vegetables in sauce, shepherds pie and lasagne, the item to be browned being already hot before switching to the top element.

Base heat



This function uses the base element only. It will crisp up your pizza or quiche base or finish off cooking the base of a pastry case on a lower shelf. It is also a gentle heat, good for slow cooking of casseroles in the middle of the oven or for plate warming.

The Browning and Base heat functions are useful additions to your oven, giving you flexibility to finish off items to perfection.

Right-hand fan oven

The right-hand oven is a fanned oven that circulates hot air continuously, which means faster, more even cooking.

The recommended cooking temperatures for a fanned oven are generally lower than a conventional oven.

Note: Please remember that all cookers vary so temperatures in your new ovens may differ to those in your previous cooker.

Operating the Ovens

Operating the left-hand multi-function oven

The multi-function oven has two controls: a function selector and a temperature setting knob (**Fig.2-16**).

Turn the function selector control to a cooking function.

Fig.2-17 shows the control set for convectional oven cooking.

Turn the oven temperature knob to the temperature required (**Fig.2-17**).

The oven heating light will glow until the oven has reached the temperature you selected. It will then cycle on and off during cooking as the oven maintains the selected temperature.

Operating the right-hand fanned oven

Turn the oven knob to the desired temperature (**Fig.2-18**).

The oven indicator light will glow until the oven has reached the temperature selected. It will then cycle on and off during cooking (**Fig.2-19**).

Function	Use
Defrost	To thaw small items in the oven without heat
Fan oven	A full cooking function, even heat throughout, great for baking
Fanned grilling	Grilling meat and fish with the door closed
Fan assisted	A full cooking function good for roasting and baking
Conventional oven	A full cooking function for roasting and baking in the lower half of the oven
Browning element	To brown and crisp cheese topped dishes
Base heat	To crisp up the bases of quiche, pizza or pastry

Table 2-1

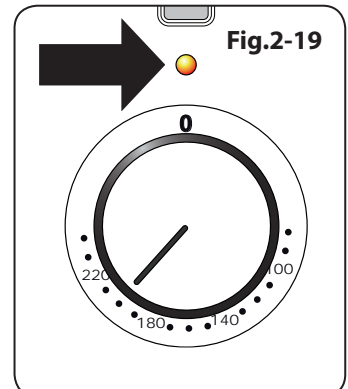
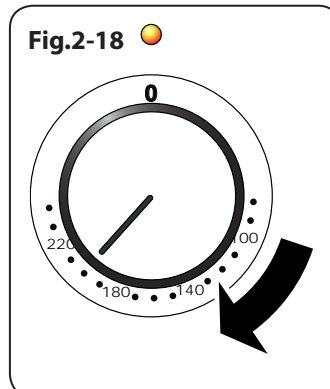
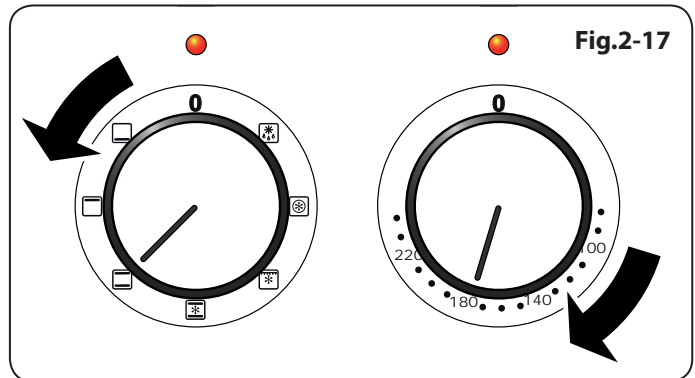
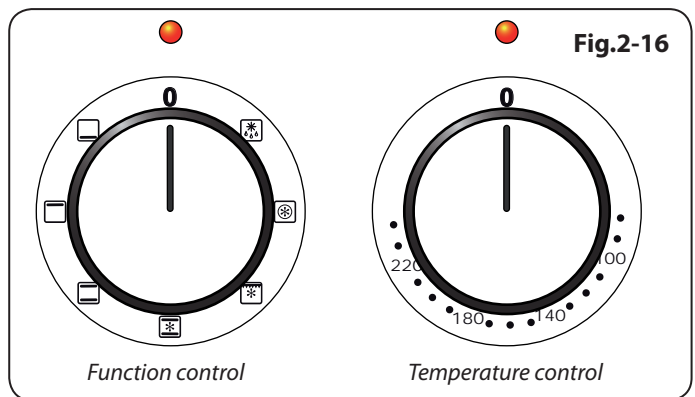

Accessories

Oven Shelves

The cooker is supplied with the following:

3 standard shelves (**Fig.2-20**)

1 drop shelf (**Fig.2-21**)

1 telescopic shelf with runners (**Fig.2-22**)

2 sets of side supports (**Fig.2-23**)

The oven shelves are retained when pulled forward but can be easily removed and refitted.

To remove and refit the racks

The rack has a small kink on either side (**Fig.2-24**). To remove the rack, line these up with the stops in the rack support (**Fig.2-25**). Lift the rack upwards so that it will pass over the rack stop and then pull it forwards (**Fig.2-26**).

Refit in the reverse order, making sure to push it fully back.

To remove and refit the telescopic rack and runners

Slide the rack out on the runners. While holding one of the runners securely, carefully lift the rear of the rack upwards: the rack will spring clear of the central restraining tab. Repeat for the opposite side of the rack.

Note: To aid the removal of the shelf you can insert a suitable flat tool through the opening in the side of the runners and lever the rack clear (**Fig.2-27**).

Tilt the front of the rack downwards and then lift clear of the runners (**Fig.2-28**).

Refit in the reverse order, making sure to push the rack down onto the runner arms.

To remove and refit the ladder rack supports

Lift the ladder support hooks out of the two locating holes in the oven side (or divider) before lifting the support clear of the bottom ladder restraint.

Refit by inserting the bottom of the ladder into the restraint before fitting the hooks through the locating holes.

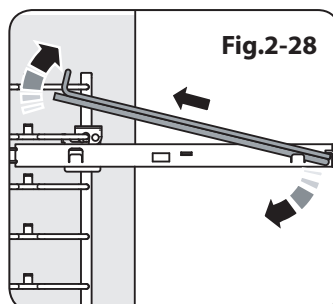
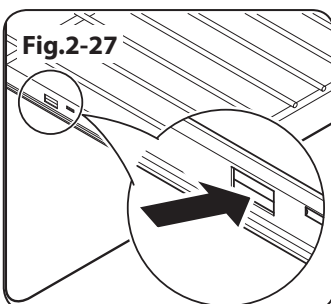
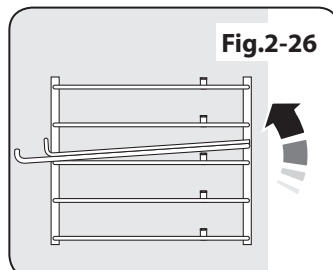
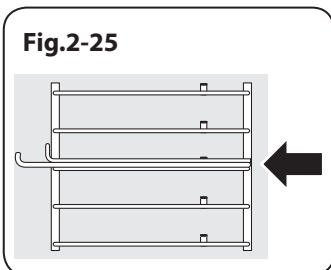
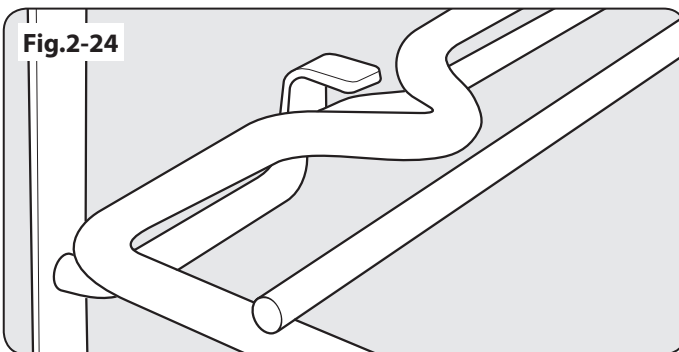
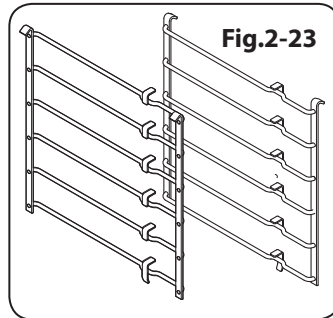
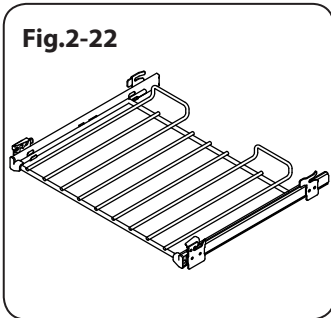
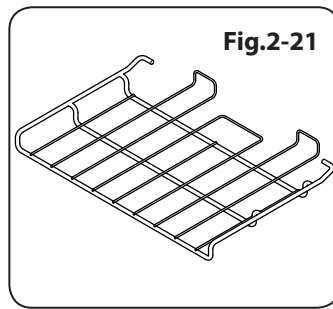
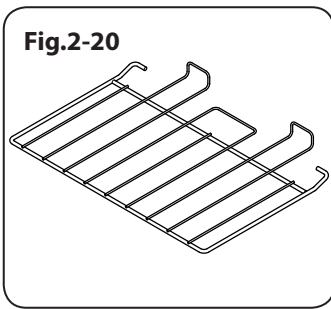

Storage

The bottom drawer is for storing oven trays and other cooking utensils.

It can get very warm, so do not store anything in it that may melt or catch fire. Never store flammable materials in the drawer. This includes paper, plastic and cloth items, such as cookbooks, plastic ware and towels, as well as flammable liquids. Do not store explosives, such as aerosol cans, on or near the appliance.

⚠ Flammable materials may explode and result in fire or property damage.

The drawer can be removed completely for cleaning, etc.

To Remove the Drawer

Pull the drawer right out.

Push the ends of the plastic clips (down of the left-hand side, up on the right-hand side) to release the catches holding the drawer to the side rails (**Fig.2-29**). At the same time pull the drawer forwards and away from the side rails.

For safety's sake push the drawer rails back out of the way.

Replace the storage drawer

To replace the drawer in the cooker, pull the side rails fully out (**Fig.2-30**).

Carefully move the drawer back between the rails and rest it on the side rails (**Fig.2-31**).

Push the drawer back so that the clips click

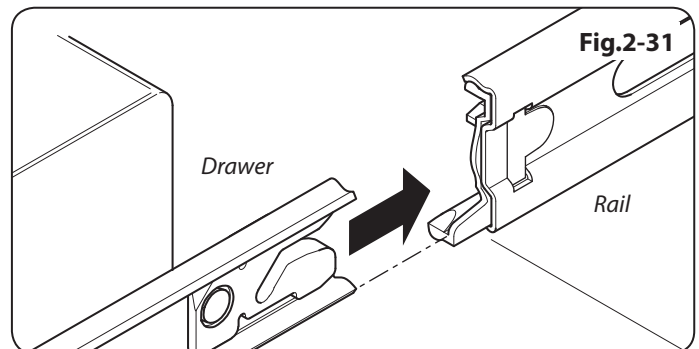
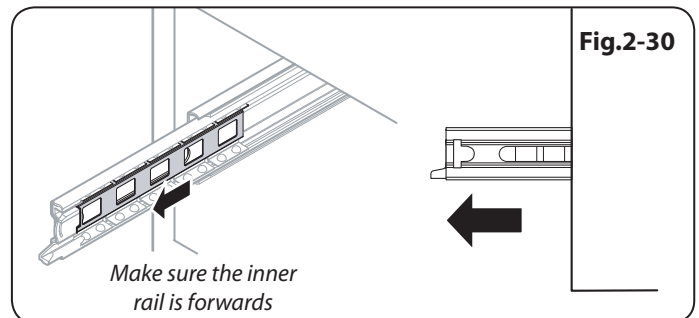
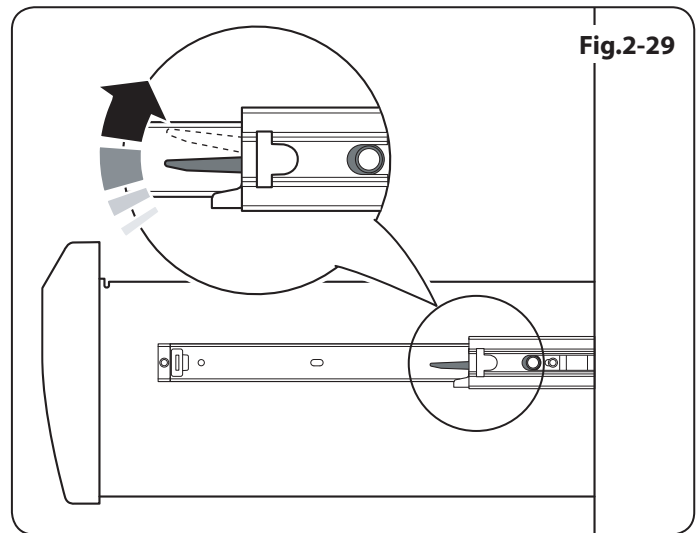

3. Cooking Tips

Cooking with a Multi-function Oven

Remember: not all modes are suitable for all food types. The oven cooking times given are intended for a guide only.

General Oven Tips

The wire shelves should always be pushed firmly to the back of the oven.

Baking trays with food cooking on them should be placed level with the front edge of the oven's wire shelves. Other containers should be placed centrally. Keep all trays and containers away from the back of the oven, as overbrowning of the food may occur.

For even browning, the maximum recommended size of a baking tray is 340mm (13½") by 340mm (13½").

When the oven is on, do not leave the door open for longer than necessary, otherwise the knobs may get very hot.

- Always leave a 'fingers width' between dishes on the same shelf. This allows the heat to circulate freely around them.
- To reduce fat splashing when you add vegetables to hot fat around a roast, dry them thoroughly or brush lightly with cooking oil.
- Where dishes may boil and spill over during cooking, place them on a baking tray.
- Sufficient heat rises out of the oven while cooking to warm plates in the grill compartment.
- If you want to brown the base of a pastry dish, preheat the baking tray for 15 minutes before placing the dish in the centre of the tray.

4. Cooking Table

The oven control settings and cooking times given in the table below are intended to be used **AS A GUIDE ONLY**. Individual tastes may require the temperature to be altered to provide a preferred result.

Food is cooked at lower temperature in a fan oven than in a conventional oven. When using recipes, reduce the fan oven temperature by 10°C and the cooking time by 5-10 minutes. The temperature in the fanned oven does not vary with height in the oven so you can use any shelf.

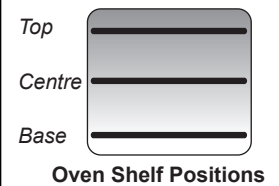

Food	Conventional Oven		Fan Oven		Approximate cooking time
	Temperature °C	Shelf position	Temperature °C	Shelf position	
Meat					
Beef (no bone)	160	C	150		30-35 minutes per 500g +30-35 minutes.
	200	C	190		20-25 minutes per 500g +20-25 minutes.
Lamb	160	C	150		30-35 minutes per 500g +30-35 minutes.
	200	C	190		25-30 minutes per 500g +25-30 minutes.
Pork	160	C	150		35-40 minutes per 500g +35-40 minutes.
	200	C	190		25-30 minutes per 500g +25-30 minutes.
Poultry					
Chicken	160	C	150		20-25 minutes per 500g +20-25 minutes.
	200	C	190		15-20 minutes per 500g +15-20 minutes.
Turkey	160	C	150		20 minutes per 500g +20 minutes.
	200	C	190		15 minutes per 500g +15 minutes.
Duck	160	C	150		25-30 minutes per 500g.
	200	C	190		20 minutes per 500g.
Casserole	140-150	C	130-140		2-4 hours according to recipe.
Yorkshire pudding	220	C	210		Large tins 30-35 minutes; individual 10-20 minutes.
Fish					
Fillet	190	C/B	180		15-20 minutes.
Whole	190	C/B	180		15-20 minutes per 500g.
Steak	190	C/B	180		Steaks according to thickness.
Cake					
Very rich fruit - Christmas, wedding, etc.	140	C/B	130		45-50 minutes per 500g of mixture.
Fruit 180 mm tin	150	C/B	140		45-50 minutes per 500g of mixture.
Fruit 230 mm tin	150	C/B	140		45-50 minutes per 500g of mixture.
Madeira 180 mm	160	C/B	150		80-90 minutes.
Queen cakes	190	C/B	180		15-25 minutes.
Scones	220	C/B	210		10-15 minutes.
Victoria sandwich					
180 mm tin	180	C/B	170		20-30 minutes.
210 mm tin	180	C/B	170		30-40 minutes.
Desserts					
Shortcrust tarts	200	C/B	190		20-30 minutes on a preheated tray.
Fruit pies	200	C/B	190		35-45 minutes.
Tartlets	200	C/B	190		10-20 minutes according to size.
Puff pastry	230	C/B	220		20-40 minutes according to size.
Meringues	100	C/B	90		2-3 hours.
Baked egg custard	160	C/B	150		45-60 minutes.
Baked sponge pudding	190	C/B	180		40-45 minutes.
Milk pudding	140-150	C/B	130-140		2 to 3 hours.
Bread	220	C	210		20-30 minutes.

5. Cleaning Your Cooker

Fig.5-1

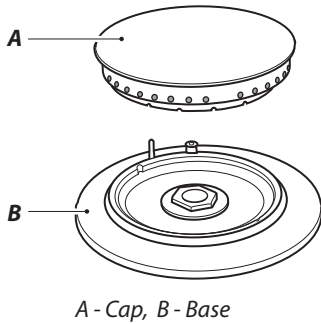

Fig.5-2

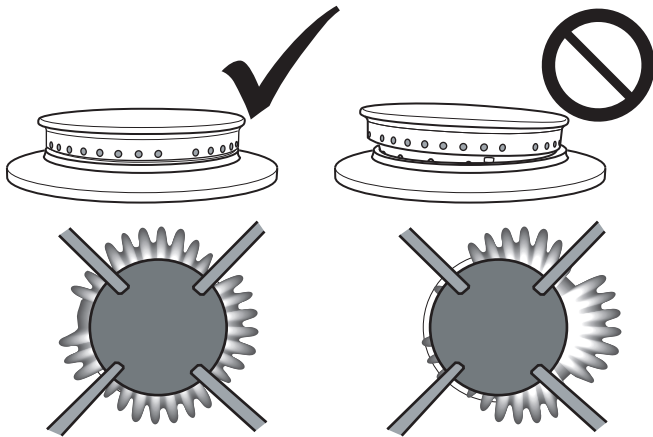
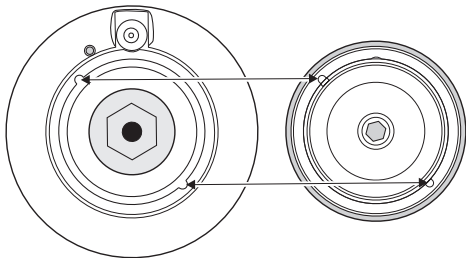

Fig.5-3



Essential Information

Isolate the electricity supply before carrying out any thorough cleaning. Allow the cooker to cool.

Never use paint solvents, washing soda, caustic cleaners, biological powders, bleach, chlorine based bleach cleaners, coarse abrasives or salt. Do not mix different cleaning products – they may react together with hazardous results.

All parts of the cooker can be cleaned with hot soapy water – **but take care that no surplus water seeps into the appliance.**

Remember to switch on the electricity supply before re-using the cooker.

We have developed a range of cleaning products that give maximum performance without damaging the enamel and painted surfaces. More information is available through either the Cookware Collection brochure supplied with your cooker or our website www.rangemaster.co.uk.

Daily Care

Cleaning the cooker is not a welcomed chore, but it has to be done to maintain efficiency and appearance. Remember it is better to wipe up any spills as they occur, this will prevent them burning on and becoming more difficult to remove later.

▲ Make sure the flow of combustion and ventilation air to the cooker is unobstructed – for example by build-up of fats or grease.

On Natural Gas the burners flames should be a bluish colour with, at most, a slight yellowish fringe.

On LP gas the flames may be “softer”. The cooktop burner flames may have a slight yellowish tip.

If the flame burns with a long white tip you should call for service.

Cleaning for Spills

For spills and boil-overs that occur while cooking, as soon as possible turn off the burner and allow to cool. Do not clean until the area is completely cooled down. Wipe up spills as soon as possible.

Do not allow surplus water to seep into the cooker.

Cooktop Burners

The burner heads and caps can be removed for cleaning. Make sure they are absolutely dry before replacing (Fig.5-1).

When replacing a burner head, make sure that it locates properly within the base (Fig.5-2). If you look at the bottom of the burner head you will see two ‘pips’ – these fit into the two notches in the burner base (Fig.5-3).

Check the burner ports are not blocked. If a blockage occurs, remove stubborn particles using a piece of fuse wire.

Stainless Steel Main Top

Lift away pots or pans from the main top. Remove grates from spillage area and carefully place in a sink of warm soapy water.

Wipe loose debris from main top. Avoid using any abrasive cleaners including cream cleaners on brushed stainless steel surfaces. For best results use a liquid detergent cleaner. Rinse with cold water and thoroughly dry with a clean, soft cloth. Ensure all parts are dry before repositioning.

Griddle (optional extra)

Always clean the griddle after use. Allow to cool completely before removing. Immerse the griddle plate in hot soapy water. Use a soft cloth or, for stubborn stains, a nylon washing up brush.

Note: If the griddle is washed in a dishwasher then some dishwasher residue may appear on the back. This is normal and will not affect the performance of your griddle.

Glide-out grill

⚠ Before you remove any of the grill parts for cleaning, ensure that they are cool, or use oven gloves.

The grill pan and grill tray assembly can be easily removed for cleaning.

Wash the grill pan and trivet washed in hot soapy water, or using our recommended Rangemaster cleaning solution.

After grilling meats or any foods that soil, leave to soak for a few minutes in the sink immediately after use. Stubborn particles may be removed from the grid by using a nylon brush.

Alternatively, wash the grill pan in a dishwasher.

To remove the grill pan pull the tray assembly forwards (**Fig.5-4**) and then lift the grill pan clear of the grill tray assembly (**Fig.5-5**).

For safety, push the grill tray back into the grill chamber.

If you need to remove the telescopic runners to allow cleaning of the grill chamber, first remove the grill tray then you can unhook them from the grill chamber sides (**Fig.5-6**).

Wipe the sides clean with a soft cloth and mild detergent.

DO NOT put the side runners in a dishwasher.

Once you have finished, hook the side rails back onto the sides of the chamber. Pull the telescopic rails out and fit the grill tray onto them, making sure to locate the cut-outs onto the telescopic runner tabs (**Fig.5-7**).

Replace the grill pan.

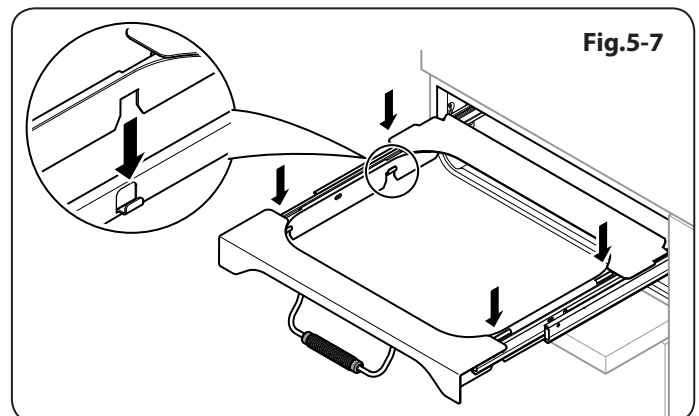
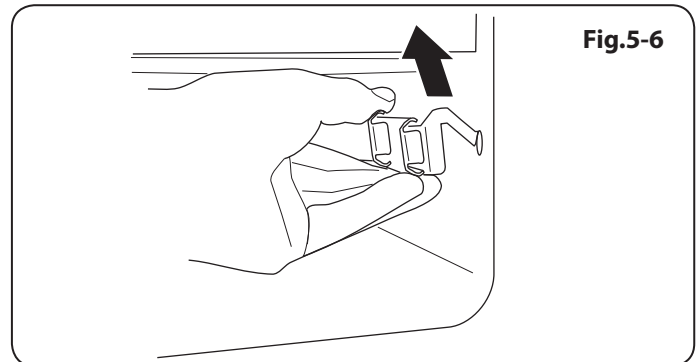
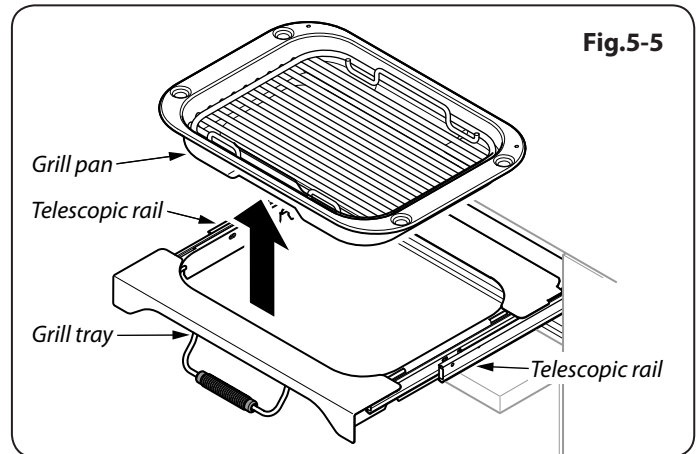
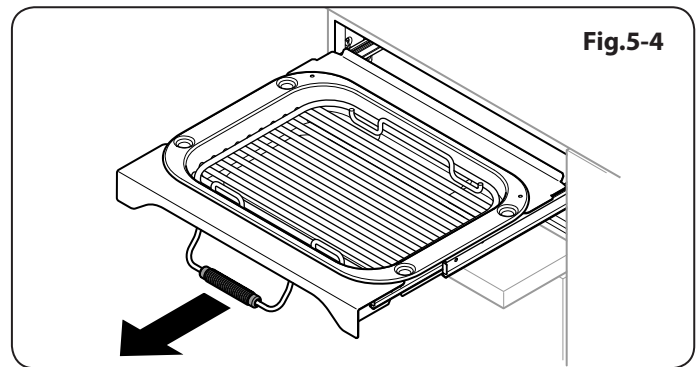

Fig.5-8

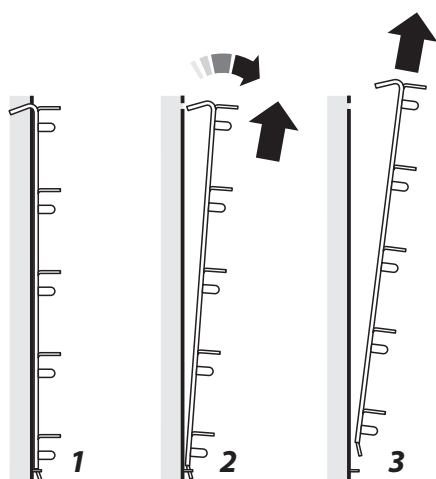
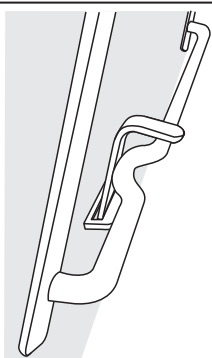

Fig.5-9



Control Panel and Oven Doors

Avoid using any abrasive cleaners including cream cleaners, on brushed stainless steel surfaces. For best results, use a liquid detergent.

The control panel and control knobs should only be cleaned with a soft cloth wrung out in clean hot soapy water – but take care that no surplus water seeps into the appliance. Wipe with a clean dampened cloth then polish with a dry cloth.

The oven doors should only be cleaned with a soft cloth wrung out in clean hot soapy water.

Ovens

'Cook & Clean' Panels

The ovens have side 'Cook & Clean' panels which have been coated with a special enamel that partly cleans itself. This does not stop all marks on the lining, but helps to reduce the amount of manual cleaning needed.

These panels work better above 200°C. If you do most of your cooking below this temperature, occasionally remove the panels and wipe with a lint free cloth and hot soapy water. The panels should then be dried and replaced and the oven heated at 200°C for about one hour. This will ensure that the panels are working effectively.

⚠ Do not use steel wool (or any other materials that will scratch the surface).

⚠ Do not use oven cleaning pads.

The oven shelf supports

The shelf supports on the oven sides can be removed for cleaning.

Removing the oven shelf supports

Remove the oven shelves. Pull the top of the shelf support up and away from the oven side and then lift the support away from the locating bracket at the bottom of the oven side (Fig.5-8).

Refitting the oven shelf supports

To refit the side support. Locate the tag at the bottom of the support into the slot in the locating bracket in the oven side (Fig.5-9). Now locate the tops of the side arms in the holes at the top and gently push down.

Cleaning Table

Cleaners listed are available from supermarkets or electrical retailers as stated.

For enamelled surfaces use a cleaner that is approved for use on vitreous enamel. The vitreous enamel association has a list of approved cleaners. Contact them via their website <http://www.ive.org.uk/> or telephone: 01527 893031.

Regular cleaning is recommended. For easier cleaning, wipe up any spillages immediately.

To help keep your oven clean, cover meat when roasting, with foil or use a roasting bag. Brush vegetables with fat before placing around the meat.

Hotplate		
Part	Finish	Recommended Cleaning Method
Hob Top	Enamel or stainless steel	Hot soapy water, soft cloth. Any stubborn stains remove gently with a nylon scourer.
Ceramic/Induction hob	Toughened glass	Hot soapy water; cream cleaner/scourer if necessary.
Griddle plate (some models only)	Non-stick surface	Allow to cool. Wash in hot soapy water. Do not use abrasive cleaners/scourers. Dishwasher.
Warming zone (some models only)	Toughened glass	Hot soapy water, cream cleaner/scourer if necessary.
Outside of cooker		
Part	Finish	Recommended Cleaning Method
Door, Door surround and Storage drawer exterior.	Enamel or paint	Hot soapy water, soft cloth. Any stubborn stains, remove gently with a liquid detergent.
	Stainless steel	E Cloth or Microfibre all purpose cloth (supermarket)
Sides and plinth	Painted surface	Hot soapy water, soft cloth
Splashback/rear grille	Enamel or stainless steel	Hot soapy water, soft cloth. Cream cleaner, with care, if necessary.
Control panel	Paint, enamel or stainless steel	Warm soapy water. Do not use abrasive cleaners on lettering.
Control knobs/handles & trims	Plastic/chrome, aluminium, copper or lacquered brass	Warm soapy water, soft cloth.
	Brass	Brass polish.
Oven door glass/Glass lid	Toughened glass	Hot soapy water, cream cleaner/scourer if necessary.
Oven and Grill		
Part	Finish	Recommended Cleaning Method
Sides, floor & roof of oven NOT COOK & CLEAN OVEN PANELS (see below)	Enamel	Any proprietary oven cleaner that is suitable for enamel. CAUTION: CORROSIVE/CAUSTIC OVEN CLEANERS: FOLLOW MANUFACTURER'S INSTRUCTIONS. Do not allow contact with the oven elements.
Cook & Clean oven panels (some models only)	Special enamel that partly cleans itself	This surface cleans itself at 200°C and above, or the panels can be removed and washed with hot soapy water and a nylon brush (see 'The Ovens' in 'Cleaning your cooker').
Oven shelves, Handyrack, Grill trivet, Handygrill rack	Chrome	An oven interior cleaner that is suitable for chrome. Soap filled pad. Dishwasher.
Grill pan/Meat tin (some models only)	Enamel	Hot soapy water. Soap filled pad. Dishwasher.

6. Troubleshooting

Hotplate ignition or cooktop burners faulty

Is the power on?

Are the sparker (ignition electrode) or burner holes blocked by debris?

Are the burner heads correctly located? See the section entitled 'Cleaning'.

Remember that each cooktop burner has a special safety device that stops the flow of gas if the flame goes out. When lighting a cooktop burner the safety device has to be overridden by holding in the control knob so that the gas can flow. This allows the flame sensor to heat up and operate the safety device. Keep holding the knob pressed in to let the gas through to the burner for few seconds. The igniter should spark and light the gas.

If, when you let go of the control knob, the burner goes out, the safety device has not held in. Turn the control to the off position and wait one minute, then try again this time holding in the control knob for slightly longer.

Hotplate burners will not light

If only one or all the cooktop burners will not light, make sure that the parts have been replaced correctly after wiping or removing for cleaning.

Check that there is not a problem with your gas supply. You can do this by making sure that other gas appliances you may have are working.

Do the burners spark when you push in the control knob? If not check the power is on.

Steam is coming from the oven

When cooking foods with a high water content (e.g. oven chips) there may be some steam visible at the rear grille. Take care when opening the oven door, as there may be a momentary puff of steam when the oven door is opened. Stand well back and allow any steam to disperse.

An oven fan is noisy

The note of the oven fan may change as the oven heats up – this is perfectly normal.

What cleaning materials are recommended for the cooker?

See the 'Cleaning' section for a full list of recommended cleaning materials.



We do not recommend corrosive or caustic cleaners as these may damage your cooker.

The knobs get hot when I use the oven, can I avoid this?

Yes, this is caused by heat rising from the oven, and heating them up. Do not leave the oven door open.

The fascia gets hot when I use the oven or grill

The cooker is cooled by a fan. If the fascia becomes excessively hot when the cooker is in use then the cooling fan may have failed. Should this occur please contact your installer, a qualified repair engineer or Customer Service to arrange for its repair.

If there is an installation problem and I don't get my original installer to come back to fix it who pays?

You do. Service organizations will charge for their call outs if they are correcting work carried out by your original installer. It is in your interest to track down your original installer.

Current Operated Ground Fault Circuit Breaker

Where the cooker installation is protected by a 30 mA sensitivity residual current device (RCD), the combined use of your cooker and other domestic appliances may occasionally cause nuisance tripping.

Food is cooking too slowly, too quickly, or burning

Cooking times may differ from your previous oven. Check that you are using the recommended temperatures and shelf positions.

See the oven cooking guide section of the instructions. The oven control settings and cooking times are intended to be used only as a guide.

Individual tastes may require the temperature to be altered either way, to get the results you want. Try cooking at a higher or lower temperature setting.

The oven is not cooking evenly

If you are cooking a large item, be prepared to turn it round during cooking.

If two shelves are used, check that space has been left for the heat to circulate. When a baking sheet is put into the oven, make sure it is placed centrally on the rack.

Check that the door seal is not damaged.

A dish of water when placed on the rack should be the same depth all over. (For example, if it is deeper at the back, then the back of the cooker should be raised up or the front lowered).

If the cooker is not level arrange for your supplier to level it for you.

Oven not coming on

Is the power on?

If not there may be something wrong with the power supply. Is the cooker supply on at the circuit breaker?

Have you set a cooking function?

Oven temperature getting hotter as the cooker gets older

If turning the knob down has not worked or only worked for a short time then you may need a new thermostat. This should be fitted by a service person.

The door is misaligned

The bottom hinge of either oven door can be adjusted to alter the angle of the door (**Fig.6-1**). Loosen the bottom hinge fixing screws and use the notch and a flat bladed screwdriver to move the position of the hinge to set the hinge position (**Fig.6-2**).

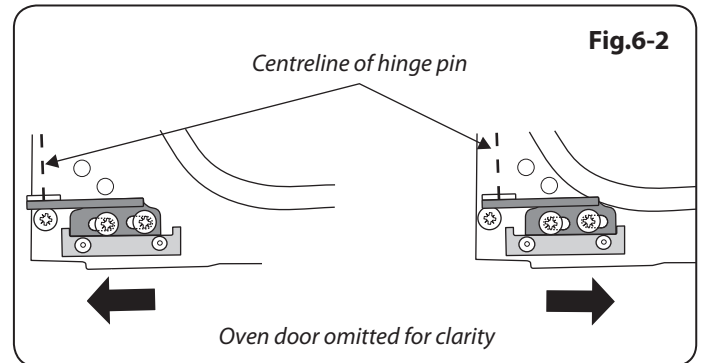
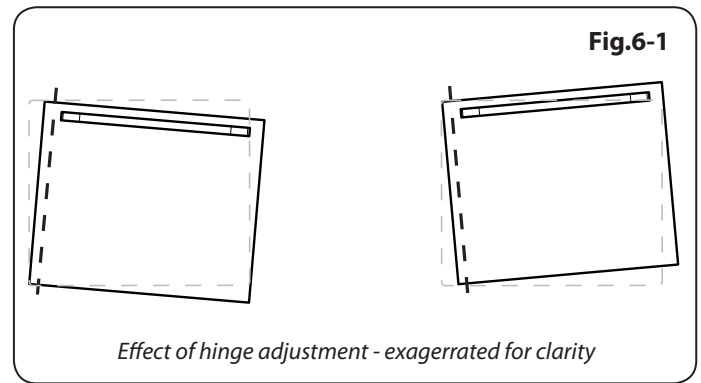

INSTALLATION

Check the appliance is electrically safe and gas sound when you have finished.

7. Installation

Dear Installer

Before you start your installation, please complete the details below, so that, if your customer has a problem relating to your installation, they will be able to contact you easily.

Installer's Name
Installer's Company
Installer's Telephone number
Appliance Serial Number

Safety Requirements and Regulations

⚠ This cooker must be installed in accordance with the relevant instructions in this booklet, with the relevant national and local regulations, and with the local gas and electricity supply companies' requirements.

⚠ This cooker is a Class 1 appliance.

Before installation, ensure that the cooker is suitable for your gas type and supply voltage. See the data badge.

The appliance must be installed in accordance with the regulations in force and only in a well-ventilated space.

Read the instructions before installing or using this appliance.

In your own interest and that of safety, it is law that all gas appliances be installed by competent persons. Failure to install the appliance correctly could invalidate any warranty or liability claims and lead to prosecution.

This appliance can be converted for use on another gas.

In the UK the cooker must be installed in accordance with:

- **All relevant British Standards / Codes of Practice, in particular BS 5440 Part 2 2000**
- **For Natural Gas – BS 6172 : 1990 and BS 6891 : 1998**
- **For LP Gas – BS 5482-1:1994 (when the installation is in a permanent dwelling). This appliance should not be installed in a boat or caravan.**
- **The Gas Safety (Installation and Use) regulations 1998.**
- **The relevant Building / IEE regulations.**

In the Republic of Ireland the cooker must be installed in accordance with:

The installation must be carried out by a competent person and installed in accordance with the current edition of IS 813 "Domestic Gas Installations", the current Building Regulations and reference should be made to the current ETCI rules for electrical installation.

Provision of Ventilation

This appliance is not connected to a combustion products evacuation device. Particular attention shall be given to the relevant requirements regarding ventilation.

All rooms require a window that can be opened, or equivalent, while some rooms require a permanent vent in addition to the window.

In the UK:

The room containing the cooker should have an air supply in accordance with BS 5440 Part 2 : 2000. All rooms require an openable window or equivalent, while some rooms require a permanent vent in addition to the openable window. The cooker should not be installed in a bedsitting room with volume less than 20m³. If it is installed in a room of volume less than 5m³ an air vent of effective area 100cm² is required; if it is installed in a room of volume between 5m³ and 10m³, an air vent of effective area 50cm² is required; while if the volume exceeds 11m³, no air vent is required.

If there are other fuel burning appliances in the same room, BS 5440 Part 2 : 2000 should be consulted to determine the requisite air vent requirements.

In the Republic of Ireland

Reference should be made to the current edition of IS 813, which makes clear the conditions that must be met to demonstrate that sufficient ventilation is available.

INSTALLATION

Check the appliance is electrically safe and gas sound when you have finished.

Location of Cooker

The cooker may be installed in a kitchen/kitchen diner but NOT in a room containing a bath or shower.

This appliance is designed for domestic cooking only. Use for any other purpose could invalidate any warranty or liability claim.

Note: An appliance for use on LPG must not be installed in a room or internal space below ground level, e.g. in a basement.

Conversion

This appliance is supplied set for G20 20 mbar Cat II 2H3+.

A conversion kit for another gas is included with the cooker.

If the appliance is to be converted to another gas we recommend that this is carried out before installation. See the instructions that are supplied with the conversion kit.

After converting the appliance, please attach the Gas Conversion sticker over the appropriate area of the data badge – this will identify the gas type for which the appliance is now set.

You will need the following equipment to complete the cooker installation satisfactorily:

- Stability bracket: If the cooker is to be supplied with gas through a flexible hose, a stability bracket or chain must be fitted.
- These are not supplied by with the cooker but are available at most builders' merchants.
- Gas pressure tester/manometer
- Flexible gas hose: Must be in accordance with the relevant standards.
- Multimeter: For electrical checks

You will also need the following tools:

1. Electric drill
2. Masonry drill bit (only required if fitting the cooker on a stone or concrete floor)
3. Wall plugs (only required if fitting the cooker on a stone or concrete floor)
4. Steel tape measure
5. Cross head screwdriver
6. Flat head screwdriver
7. Spirit level
8. Pencil
9. Adjustable spanner
10. Screws for fitting stability bracket
11. 3mm Allen keys

Checking the Parts:

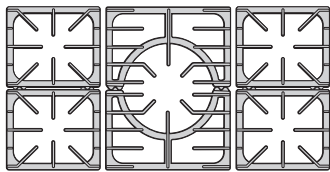
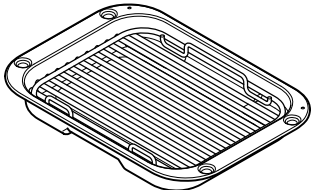
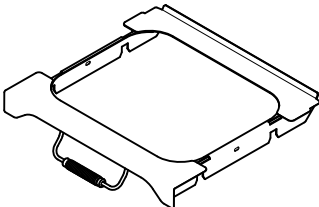
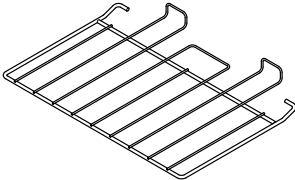
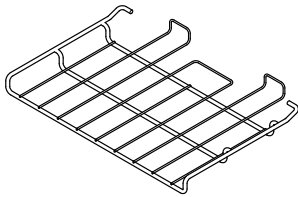
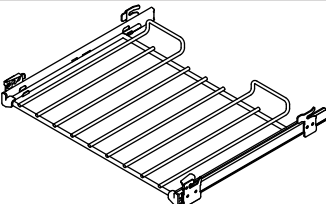
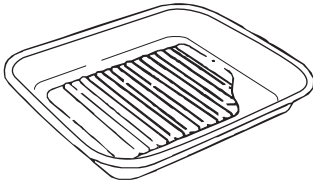
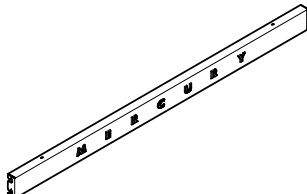
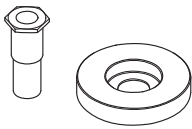
<i>5 pan supports</i> 	<i>Grill pan & trivet</i> 
<i>Grill pan cradle</i> 	<i>3 flat shelves</i> 
<i>1 drop shelf</i> 	<i>1 telescopic shelf</i> 
<i>Roasting tin</i> 	<i>Plinth</i> 
<i>Conversion kit</i> 	

INSTALLATION

Check the appliance is electrically safe and gas sound when you have finished.

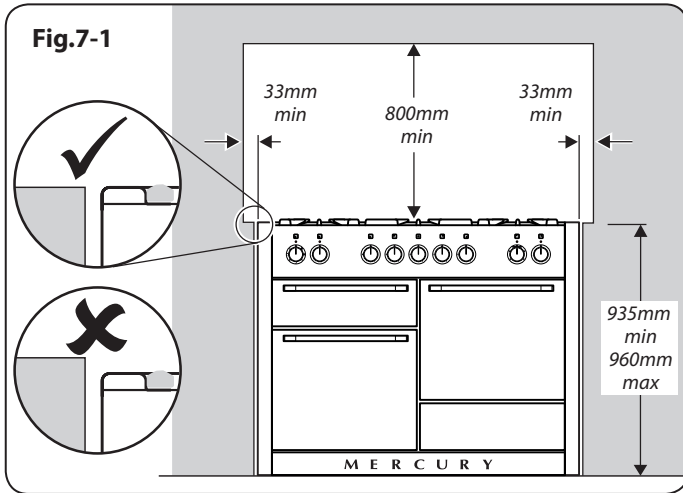

Positioning the Cooker

Fig.7-1 shows the minimum recommended distance from the cooker to nearby surfaces.

The cooker should not be placed on a base.

Above hotplate surround should be level with, or above, any adjacent work surface.

A gap of 33 mm should be left between each side of the cooker **ABOVE** the hotplate level and any adjacent vertical surface.

For non-combustible surfaces (such as unpainted metal or ceramic tiles) this gap is not required.

A minimum space of 800 mm is required between the top of the hotplate and a horizontal combustible surface.

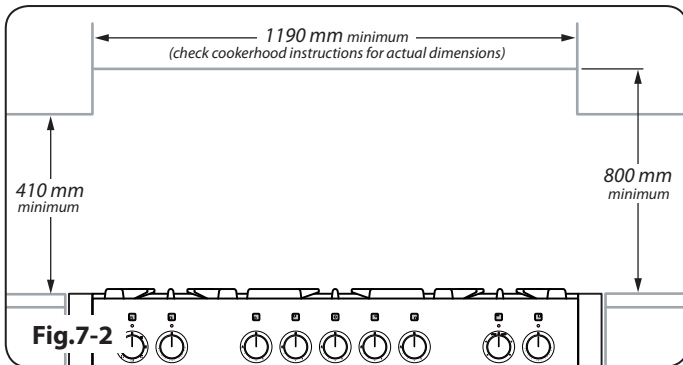
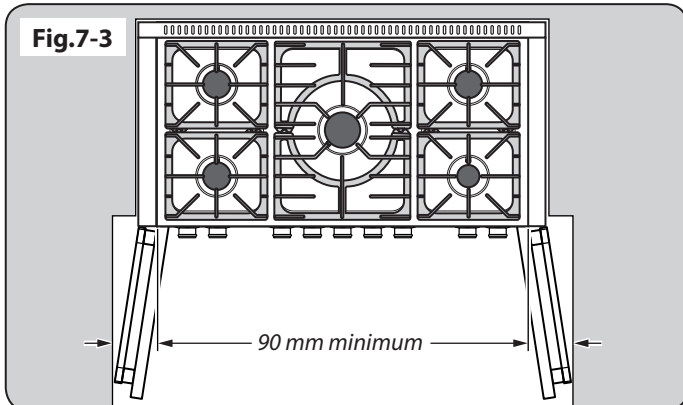

Fig.7-2 shows the suggested clearances above the cooker.

*** Any cooker hood should be installed in accordance with the hood manufacturer's instructions.**

Surfaces of furniture and walls at the sides and rear of the appliance should be heat, splash and steam resistant. Certain types of vinyl or laminate kitchen furniture are particularly prone to heat damage and discolouration.

We cannot accept responsibility for damage caused by normal use of the cooker to any material that de-laminates or discolours at temperatures less than 65°C above room temperature



We recommend a gap of 1200 mm between units to allow for moving the cooker. Do not box the cooker in – it must be possible to move the cooker in and out for cleaning and servicing.

A clearance of 90 mm is required if the cooker is near a corner of the kitchen to allow the oven doors to open (**Fig.7-3**). The actual opening of the doors is slightly less but this allows for some protection of your hand as you open the door.

Moving the Cooker

⚠ On no account try and move the cooker while it is plugged into the electricity supply.

⚠ The cooker is very heavy, so take great care.

We recommend that two people manoeuvre the cooker. Ensure that the floor covering is firmly fixed, or removed, to prevent it being disturbed when moving the cooker around.

To help you, there are two levelling rollers at the back, and two screw-down levelling feet at the front. You will need the levelling tool.

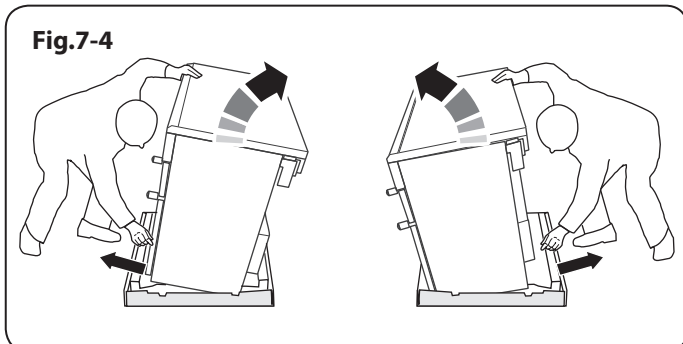

Remove the polystyrene base pack. From the front, tilt the cooker forward and remove the front half of the polystyrene base (**Fig.7-4**). Repeat from the back and remove the rear half of the polystyrene base.

INSTALLATION

Check the appliance is electrically safe and gas sound when you have finished.

Removing the Storage Drawer

Pull the drawer out to its furthest point.

Push the ends of the plastic clips – down on the left-hand side, up on the right-hand side – to release the catches holding the drawer to the side runners. At the same time pull the drawer forward and away from the side runners (**Fig.7-5**).

For safety's sake push the drawer runners back out of the way and put the drawer somewhere safe until the installation is complete.

Now LOWER THE TWO REAR ROLLERS. First fit the levelling tool on the hexagonal adjusting nut, at both the front bottom corners of the cooker (**Fig.7-6**). Make 10 complete (360°) turns clockwise (**Fig.7-7**). (This means turning and removing the levelling tool 20 times.)

Completing the Move

Unfold the rear edge of the pack base tray. Open the grill door and right-hand oven door so that you can get a good grip on the bottom of the fascia panel as you move the oven (**Fig.7-8**).

Carefully push the cooker backwards off the pack base. Remove the pack base tray.

Position the cooker close to its final position, leaving just enough space to get behind it.

⚠ Do not use the door handles or control knobs to manoeuvre the cooker.

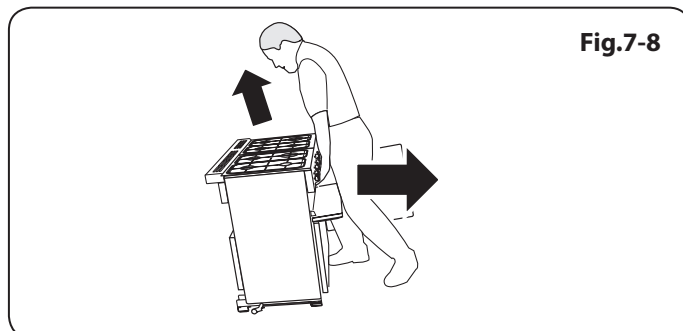
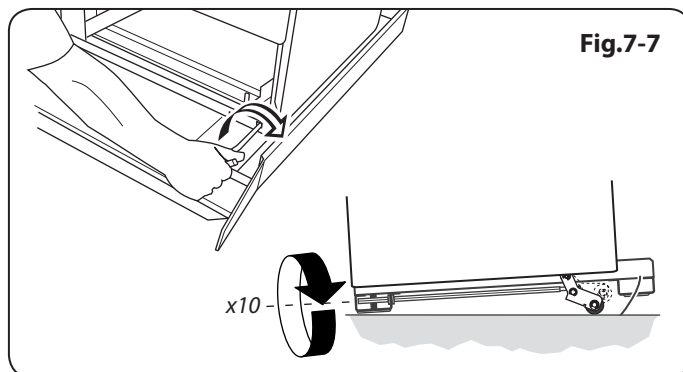
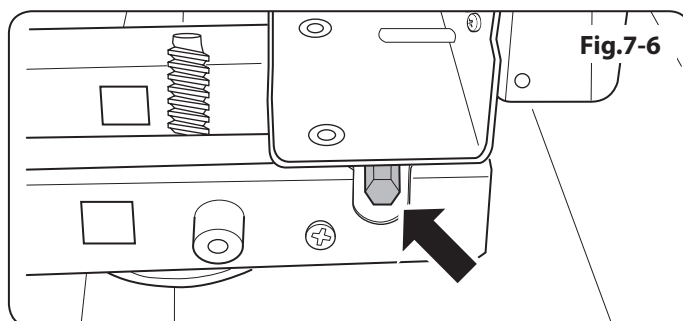
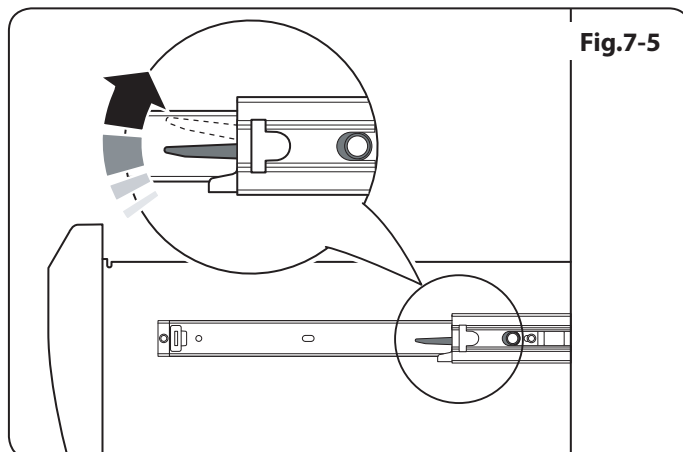

INSTALLATION

Check the appliance is electrically safe and gas sound when you have finished.

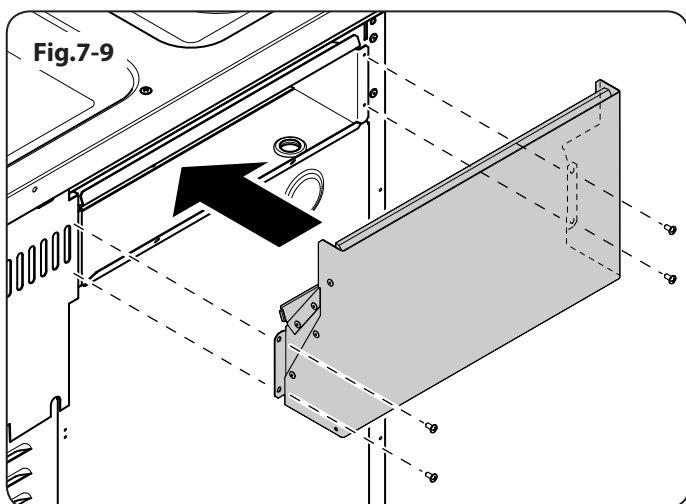

Fitting the Flue

Remove the four screws from the grill flue opening.

Offer the removable flue up to grill flue opening. Making sure that the removable flue bottom flange fits inside the fixed flue, secure in place with the four screws (**Fig.7-9**).

Installing the Flue Vent

The larger of the holes along the sides are for screwdriver access and should face to the rear (**Fig.7-10**). Use the screws and nuts supplied to hold the vent in place.

The Side Panels

Fitting the Retaining Brackets

First fit the two side panel retaining brackets onto the rear of the cooker (**Fig.7-11**) and secure.

Fitting the Side Panels

Inside the top of the side panel top are two tabs. Locate these tabs onto the front part of the hotplate brackets (**Fig.7-12**).

Slide the side panel back so that the slot in the base locates onto the rear bracket washer (**Fig.7-13**), and the slotted tab at the top rear locates onto the screw in the flue vent (**Fig.7-14**).

Push the side panel back so that it touches the rear flue. Tighten the screw in the vent to secure the side panel in position (**Fig.7-15**).

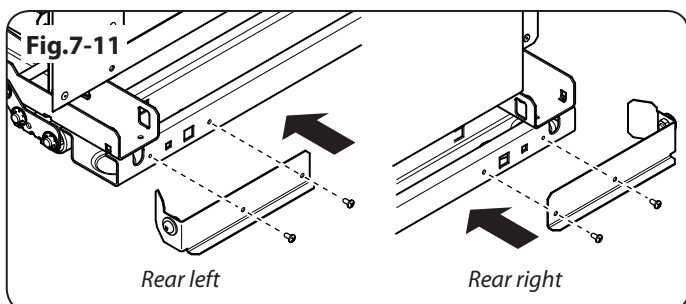
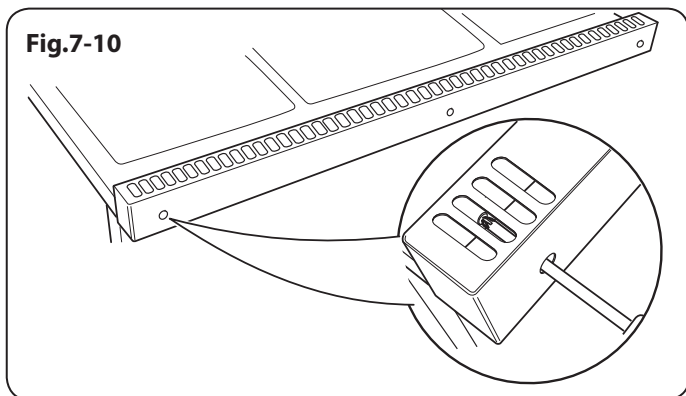

Fitting a Stability Bracket

A stability bracket or chain (not supplied by with the cooker) should be fitted when the cooker is connected to a flexible gas supply.

When fitting a stability bracket, read these instructions together with the leaflet supplied with the bracket.

1. Place the cooker in its intended position and level the cooker.
2. Draw a pencil line 70 mm from the front edge of the levelling feet.
3. Mark the centre line for the bracket by measuring 550 mm from the right-hand side of the cooker.
4. Move the cooker forward.
5. Measure back from the pencil line 550 mm to locate the front edge of the bracket (**Fig.7-16**).
6. Fix the bracket to the floor.
7. Measure the height from floor level to engagement edge in back of cooker. Add 3 mm to this dimension and assemble the stability bracket to this height (i.e. from floor level to underside of the top member). Make sure the bracket does not trap the electrical connection cable or gas hose and does not foul the oven burner assembly (**Fig.7-17**).

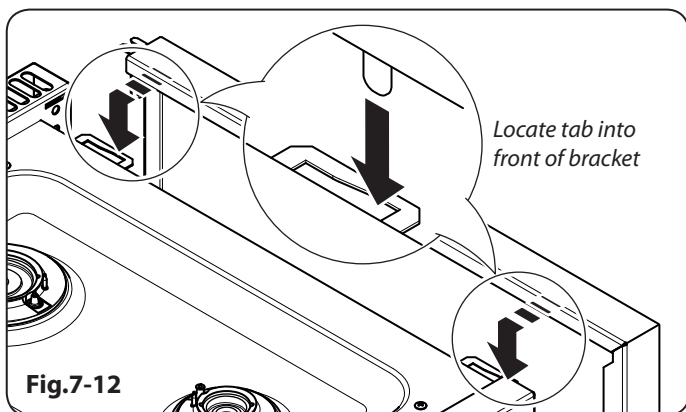

INSTALLATION

Check the appliance is electrically safe and gas sound when you have finished.

Repositioning the Cooker following Connection

If you need to move the cooker once it has been connected then you need to unplug it and, having gripped under the fascia panel and lifted the front of the cooker slightly (**Fig.7-8**), you need to check behind the cooker to ensure that the gas hose is not caught.

As you progress, make sure that both the electricity cable and gas hose always have sufficient slack to allow the cooker to move.

With a stability chain fitted, release it as you ease the cooker out. Do not forget to refit it when you replace the cooker.

When you replace the cooker, again check behind to make sure that the electricity cable and gas hose are not caught or trapped.

Conversion to Another Gas

If the appliance is to be converted to another gas do the conversion at this point. See the conversion section of these instructions and see the instructions in the conversion kit.

Levelling

You are recommended to use a spirit level on a shelf in one of the ovens to check for level.

Place the cooker in its intended position taking care not to twist it within the gap between the kitchen units as damage may occur to the cooker or the units.

The front feet and rear rollers can be adjusted to level the cooker. To adjust the height of the rear of the cooker use the levelling tool supplied to turn the adjusting nuts at the front bottom corners of the cooker. To set the front turn the feet bases to raise or lower.

Gas Connection

This must be in accordance with the relevant standards.

The flexible hose (not supplied with the cooker) must be in accordance with the relevant standards. Hoses may be purchased at most builders' merchants.

The gas supply needs to terminate with a down facing bayonet.

The connector is located just below the hotplate level at the rear of the cooker. If in doubt contact your supplier.

The rear cover boxes limit the position of the supply point.

Because the height of the cooker can be adjusted and each connection is different, it is difficult to give precise dimensions.

Although a 900 mm hose can be used, a 1250 mm hose will allow slightly more flexibility in the positioning of the bayonet and make moving the cooker easier.

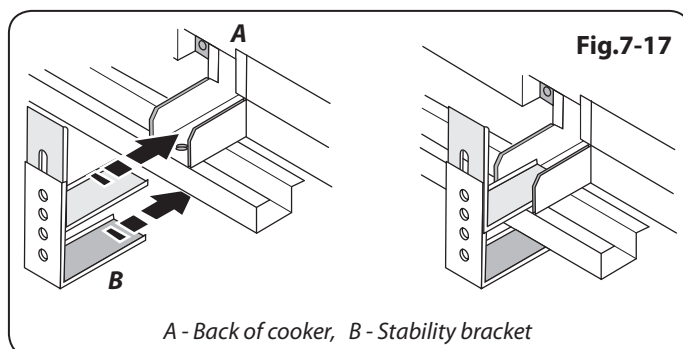
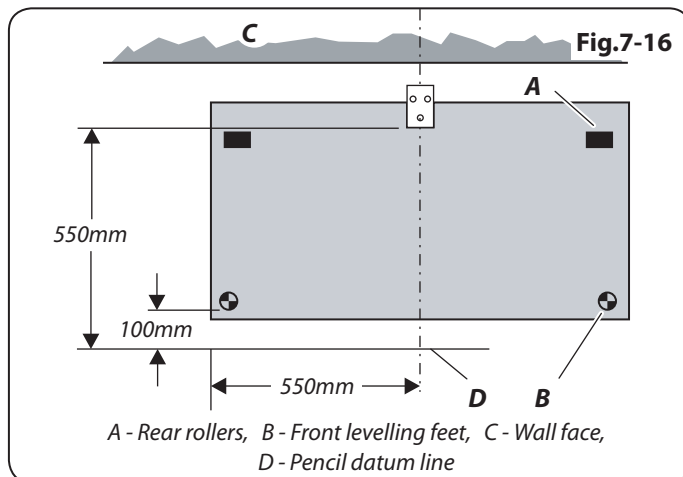
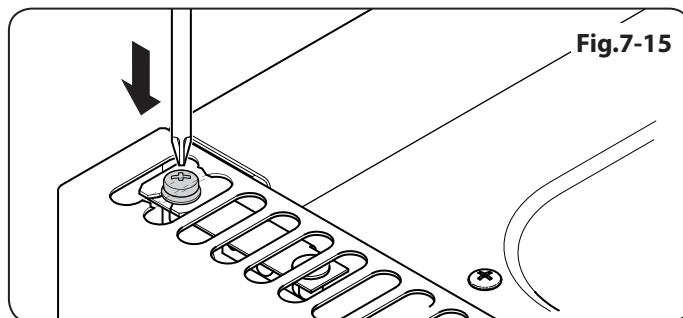
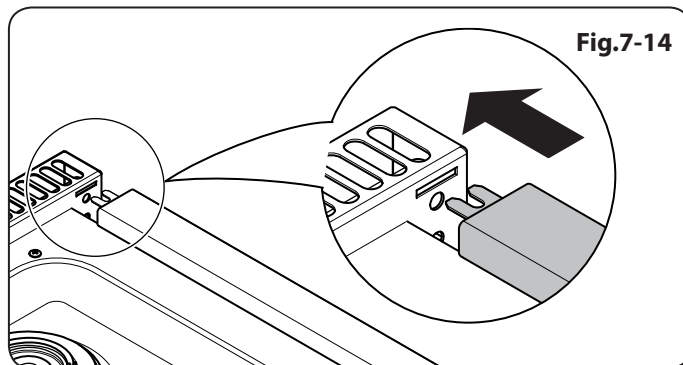
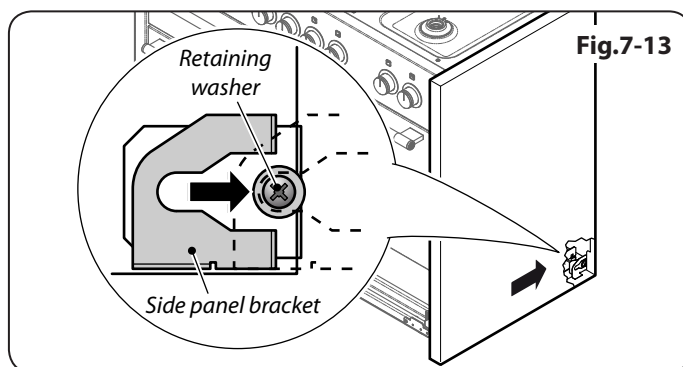

INSTALLATION

Check the appliance is electrically safe and gas sound when you have finished.

Fig.7-18

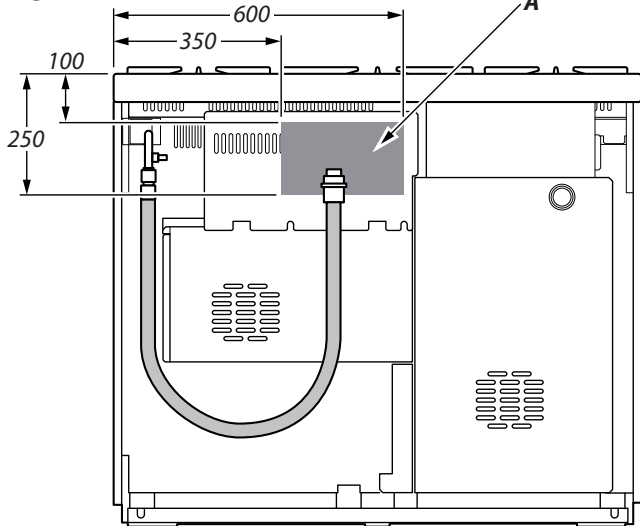

The hose should be fitted so that both inlet and outlet connections are vertical so that the hose hangs downwards in a 'U' shape. Ideally the hose supply connection should be within the shaded area 'A' shown (Fig.7-18).

For Natural Gas, the flexible hose must be in accordance with BS 669. For LP Gas, it should be capable of 50mbar pressure, 70°C temperature rise, and carry a red stripe, band or label. If in doubt contact your supplier.

Screw connect the threaded end of the hose into the gas inlet.

After completing the gas connection, ensure that the cooker is gas sound with a pressure test.

Pressure Testing

The gas pressure can be measured at one of the centre hotplate burner injectors (not the Wok burner).

The gas pressure can be measured at the injector of one of the left-hand hotplate burners.

Lift off a burner head. Fit the pressure gauge to the injector. Turn on and light one of the other hotplate burners.

Turn on the control knob for the burner with the pressure gauge fitted to let gas through.

See the data badge for test pressures.

Turn off the burners. Make sure that you reassemble the burner top in the correct way on the burner body.

Fig.7-19

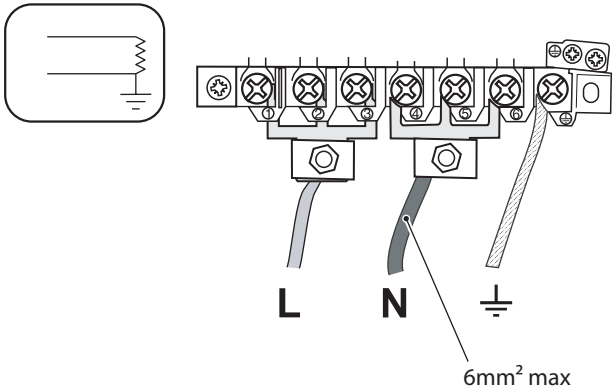

Electrical Connection

The cooker must be installed by a qualified electrician, in accordance with all relevant British Standards/Codes of Practice (in particular BS 7671), or with the relevant national and local regulations.

Current Operated Earth Leakage Breakers

The combined use of your cooker and other domestic appliances may cause nuisance tripping, so we recommend that the cooker is protected on an individual RCD (Residual Current Device) or RCBO (Residual Current Breaker with Overload).

IF IN DOUBT, PLEASE CONSULT A SUITABLY QUALIFIED ELECTRICIAN.

Note: The cooker must be connected to the correct electrical supply as stated on the voltage label on the cooker, through a suitable cooker control unit incorporating a double pole switch, having a contact separation of at least 3mm in all poles.

The cooker must not be connected to an ordinary domestic power point.

Access to the mains terminal is gained by removing the electrical terminal cover box on the back panel. Connect the mains cable to the correct terminals for your electrical supply type (Fig.7-19). Check that the links are correctly fitted and that the terminal screws are tight. Secure the mains cable using the cable clamp.

INSTALLATION

Check the appliance is electrically safe and gas sound when you have finished.

Hotplate Check

Check each burner in turn (refer to the 'Hotplate Burners' section at the front of the instructions).

Grill Check

Turn on the grill control and check that the grill heats up.

Oven Check

Set the clock as described earlier in the instructions, and then turn on the ovens. Check that the oven fans start to turn and that the ovens start to heat up.

Note: The oven light bulb is not included in the guarantee.

Turn off the oven.

Final Fitting

Fitting the Plinth

Open the left-hand oven door and make sure the storage drawer is removed.

Note: For safety's sake make sure the drawer runners are out of the way.

On the front on the cooker base there are two mounting plates. Remove the three fixing screws from each plate.

Fit the retaining brackets to the mounting plates and refit the screws (**Fig.7-15**). DO NOT tighten at this stage.

Fit the plinth onto the brackets and hold in place using the two screws provided. DO NOT tighten at this stage.

Adjust the plinth to align it with the door panels and the side panels. When it is positioned correctly, use a suitable flat open ended spanner to tighten the bracket screws, and then tighten the plinth screws.

Refitting the Drawer

To refit the drawer, pull the side rails fully out (**Fig.7-22**).

Carefully move the drawer back between the rails and rest it on the side rails.

At each side, hold the front of the drawer and pull the side rail forward so that the clips click into position, holding the drawer to the side rails (**Fig.7-23**).

Customer Care

Installer: Please complete your details in this Guide, inform the user how to operate the cooker and hand over the instructions.

Thank you.

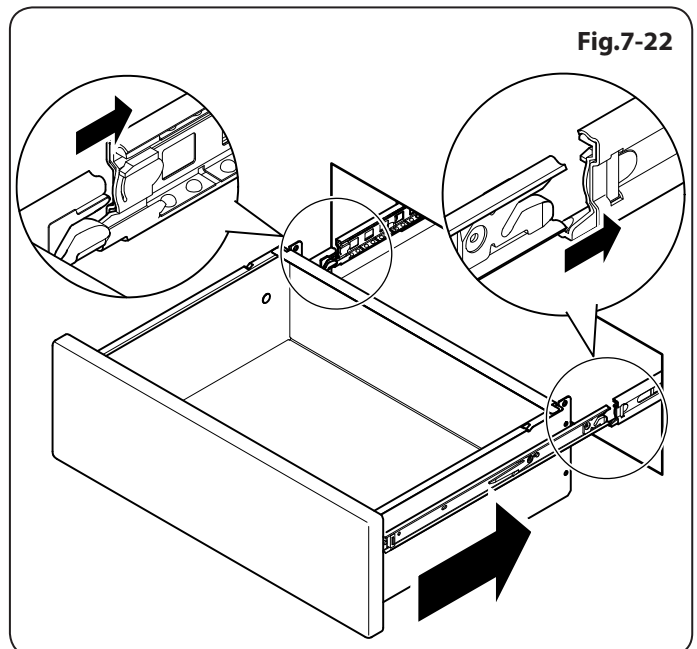
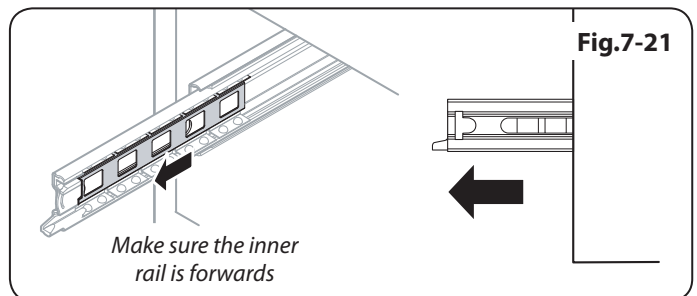
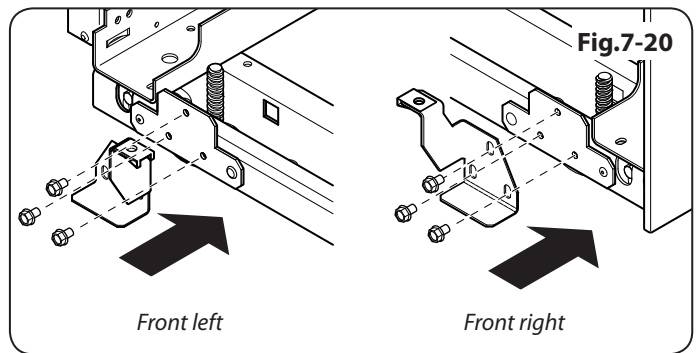

WARNING – SERVICING TO BE CARRIED OUT ONLY BY AN AUTHORISED PERSON
Disconnect from electricity and gas before servicing. Check appliance is safe when you have finished.

8. Conversion to LP gas

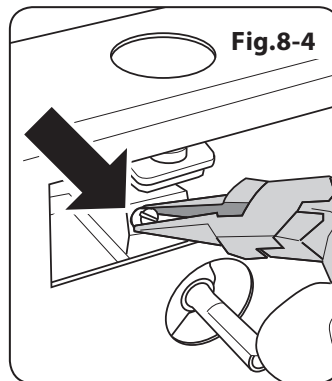
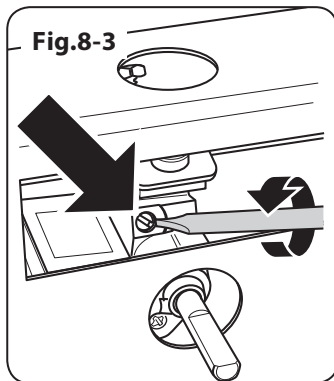
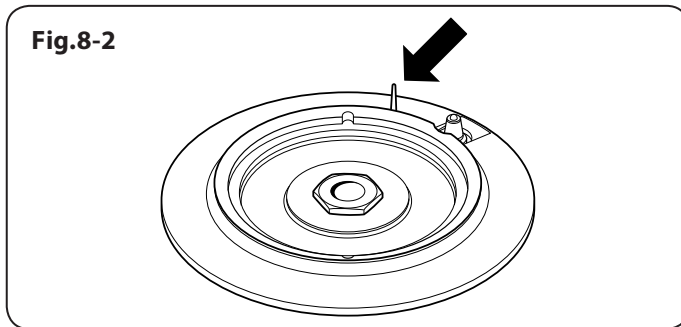
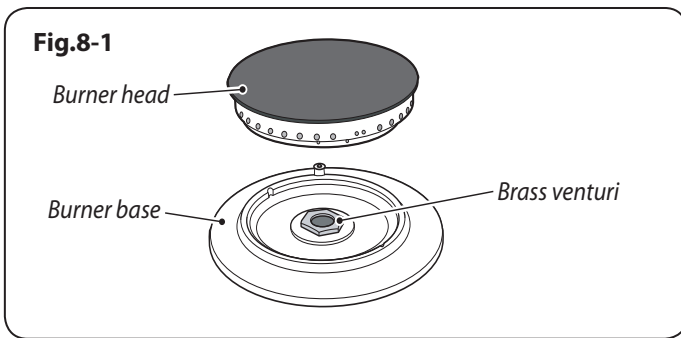

	Natural Gas	Propane Gas
Centre burner	205	118
Large burners	150	99
Right front burner	112	68

Table 8-1

	Natural Gas	Propane Gas
Hotplate	Bypass	Bypass
Centre burner	82	49
Large burners	70	38
Right front burner	53	31

Table 8-2

Check the technical data section at the back of the book that the hob is convertible to the gas you want to use.

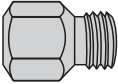
A suitably competent person must perform the conversion. After conversion the installation must comply with the relevant regulations and also the local electricity supply company requirements. Read the instructions before converting this appliance.

⚠ Failure to convert the appliance correctly could invalidate any warranty or liability claims and lead to prosecution.

When servicing or replacing gas-carrying components disconnect from the gas supply before starting operation. Check the appliance is gas sound after completion.

DO NOT use reconditioned or unauthorised gas controls.

⚠ Disconnect from the electricity supply before servicing. Before electrical reconnection, check that the appliance is electrically safe.

Injectors

Remove the pan supports and burner heads. Undo the large brass nut on the top of the brass venturis and remove (Fig.8-1).

Removing the jets

First remove the service plate.

Either:

Use a long box spanner to access and remove the old jets;

Or:

Lift up the front of the hotplate top and prop it up to access the burner bases. Remove the old jets.

Save the jets removed from the appliance for possible future use. Fit the new jets: see Table 8-1 for the correct type.

Note: If you have lifted up the hotplate then carefully replace it taking care not to damage or displace the ignition electrodes or flame safety probes (Fig.8-2) and replace the rear fixing screws.

Tap adjustment

Pull off all the control knobs. Open the grill door and right-hand oven door and remove the fixing screws underneath the control panel. Remove the 3 fixing screws at the top of the control panel.

Pull the control panel forward. Taking care not to damage it, by protecting it with cloth for example, rest it on the open grill door and oven door.

Unscrew the control valve bypass screw (Fig.8-3). Using a pair of long nose pliers, carefully remove the bypass screw (Fig.8-4).

Install the correct replacement screw. See Table 8-2 for the correct size. Tighten the screw down.

Repeat for all burner control taps.

WARNING – SERVICING TO BE CARRIED OUT ONLY BY AN AUTHORISED PERSON
Disconnect from electricity and gas before servicing. Check appliance is safe when you have finished.

Refit the control panel.

Note: Save the removed bypass screws for possible future reversion to Natural gas.

Reassembling to Liquid Propane Gas

Centre burner

IMPORTANT: If you are converting to LP Gas the large ring in the conversion kit **MUST** be fitted to the centre burner.

Fit the large ring (if required). Screw in the hexagon headed venturi but to make fitting the outer burners easier do not fully tighten yet (**Fig.8-5**).

Outer burners

Screw in the hexagon headed venturis (**Fig.8-6**) but to make fitting the other burners easier do not fully tighten yet.

Reassemble all the burners with the venturi tubes and evenly tighten.

Refit the burner heads, making sure they are reassembled in the correct way on the burner bodies (**Fig.8-7**).

Refit the pan supports.

Reassemble in the reverse order.

Stick on Label

Stick the appropriate label on to the data badge to indicate the gas the appliance is now set for.

Pressure Testing

Connect the appliance to the gas supply.

- ⚠ Check the appliance is gas sound.**
- ⚠ CAUTION: DO NOT use a flame to check for gas leaks.**
- ⚠ Check the operation of all the burners.**

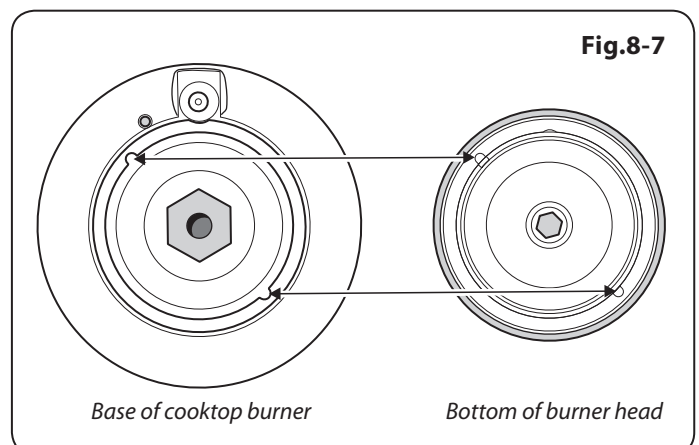
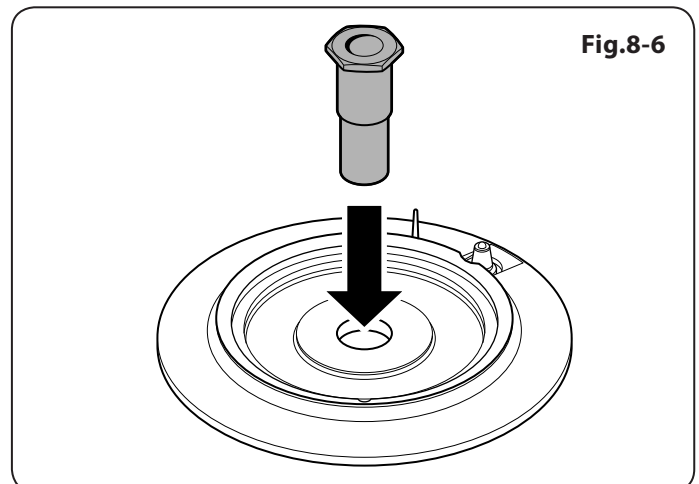
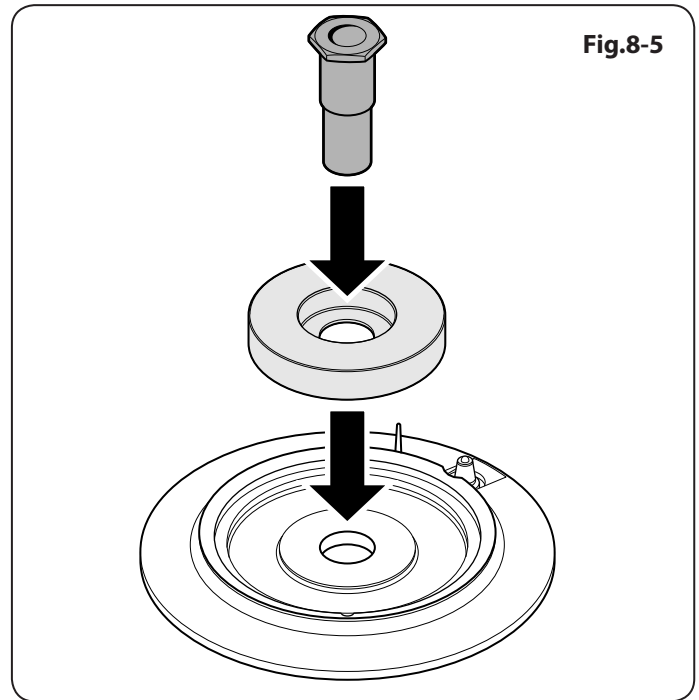

9. Circuit Diagram

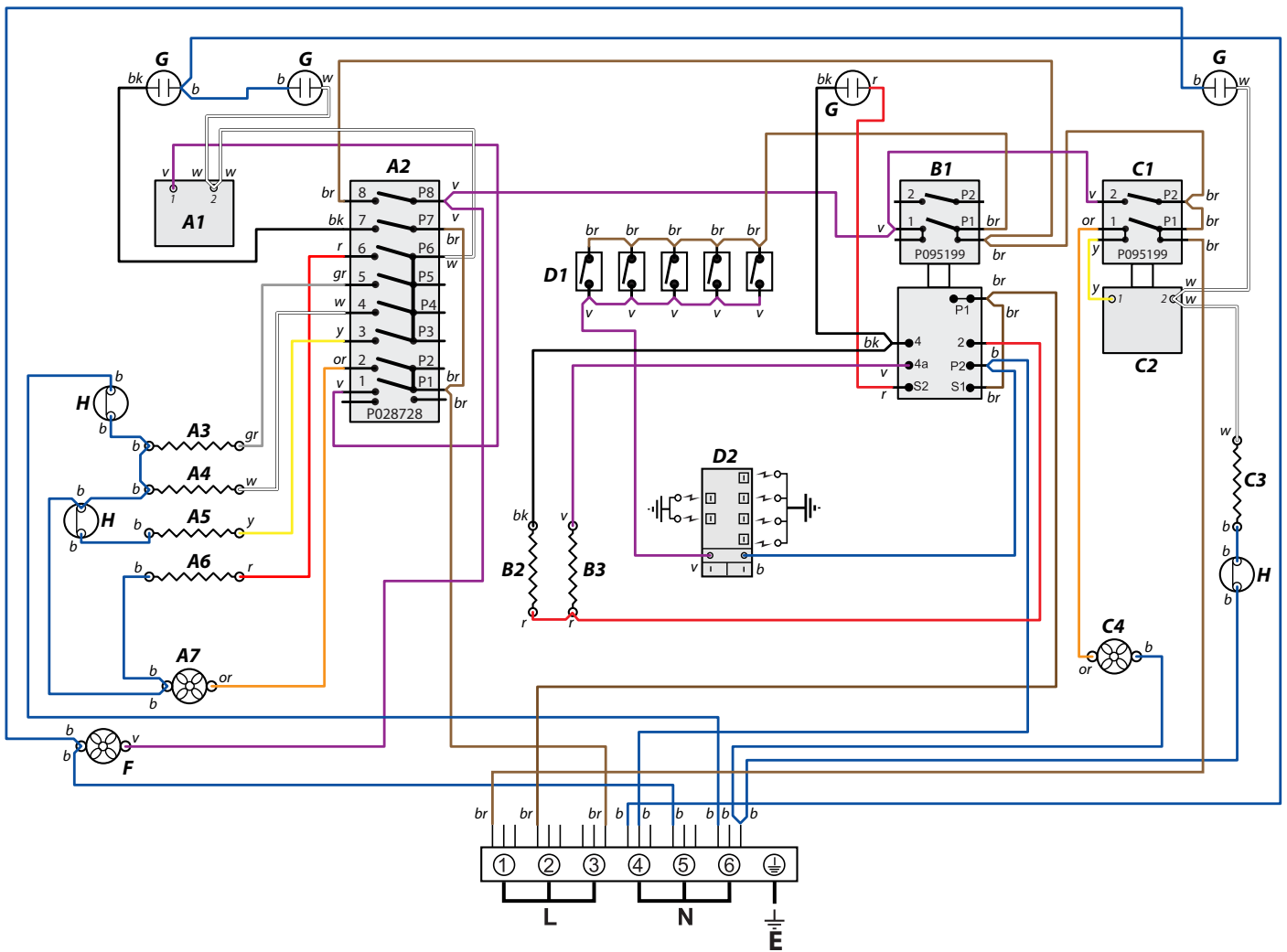

Key

The connections shown in the circuit diagram are for single-phase. The ratings are for 240 V 50 Hz.

Code	Description
A1	Left-hand MF oven control
A2	Left-hand MF oven control switch
A3	Left-hand MF oven top element (outer pair)
A4	Left-hand MF oven browning element (inner pair)
A5	Left-hand MF oven fan element
A6	Left-hand MF oven base element
A7	Left-hand MF oven oven fan
B1	Grill control
B2	Left-hand grill element
B3	Right-hand grill element

Code	Description
C1	Right-hand fan oven control
C2	Right-hand fan oven thermostat
C3	Right-hand fan oven element
C4	RH oven fan
D1	Ignition switches
D2	Ignition generator
F	Cooling fan
G	Neon
H	Thermal cut-out

Colour Code	
b	Blue
br	Brown
bk	Black
or	Orange
r	Red
v	Violet
w	White
y	Yellow
g/y	Green/yellow
gr	Grey

10. Technical Data

The cooker is category II2H3+

It is supplied set for group H natural gas. A conversion kit from NG to LP is packed with the cooker.

INSTALLER: Please leave these instructions with the User.

DATA BADGE LOCATION: Cooker back, serial number repeater badge below oven door opening.

Connections

Gas (Rp ½ at rear right-hand side)		Electric
Natural gas	20 mbar	220-240V 50Hz
Butane	29 mbar	
Propane	37 mbar	

(See the appliance badge for test pressures)

Dimensions

Height (to top of side panel)	minimum 935 mm	maximum 960 mm
Height (to top of fascia)	minimum 935 mm	maximum 960 mm
Overall width	1190 mm	
Overall depth	638 mm to front of fascia; 700 mm over handles	

Refer to 'Positioning the Cooker'.

Ratings

Hotplate	Natural Gas 20 mb			L.P. Gas		
		Injector	Screw		Injector	Screw
Wok burner	5.0 kW	165	96	5.0 kW (357/h)	107	57
Large burner	3.0 kW	120	54	3.0 kW (214 g/h)	85	40
Small burner	1.7 kW	95	38	1.7 kW (121 g/h)	64	28

Output/Oven	Left-hand multi-function	Right-hand fan
Maximum output	2.5 kW	2.5 kW

Oven Efficiency

Ovens	Left-hand oven	Right-hand oven
	Multi-function	Forced air convection
Energy efficiency class on a scale of A (more efficient) to G (less efficient)	B	A
Energy consumption based on standard load	0.90 kWh	0.85 kWh
Usable volume (litres)	62	67
Size	Large	Large
Time to cook standard load	41 minutes	38 minutes
Surface area of the grid	1400 cm ²	1400 cm ²

Grill	2.3 kW
-------	--------

Maximum total electrical load at 230 V 7.4 kW (approximate total including oven lights, oven fan, etc.)

AGA RANGEmaster

Clarence Street, Royal Leamington Spa,
Warwickshire, CV31 2AD, England.

Tel: +44 (0) 1926 457000 Fax: +44 (0) 1926 450526

E-mail: consumers@agarangemaster.co.uk